

# BROADCAST NEWS

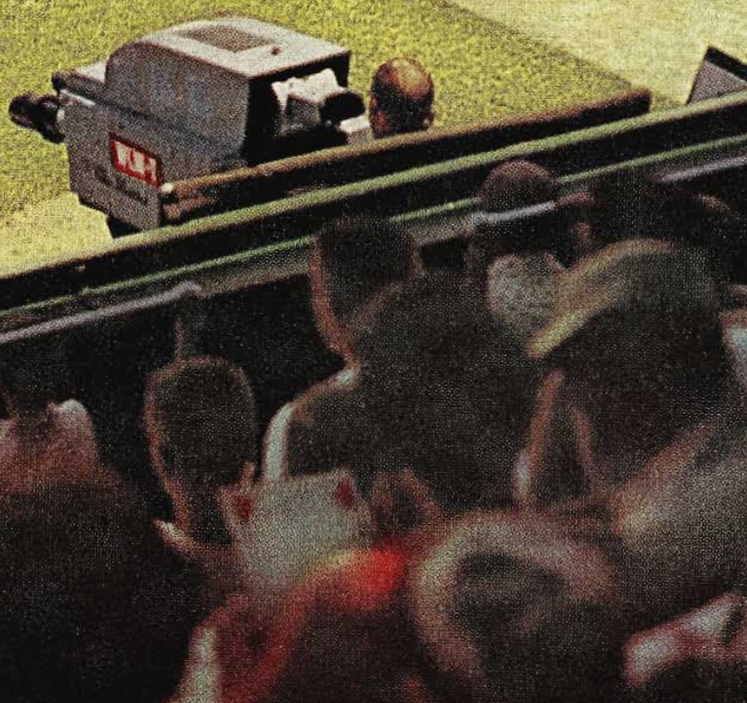

VOL. No. 105  
SEPTEMBER 1959

WLW-T COLORCASTS  
BIG LEAGUE BASEBALL



ANOTHER WAY RCA SERVES  
BROADCASTERS THROUGH  
ELECTRONICS



## Now...pick an effect from more than 150 possibilities!



Here's the ultimate in convenience for selection and presentation of program effects—the all new RCA Special Effects System. Key circuitry for each effect is contained in plug-in modules. Any ten effects may be pre-selected—simply plug ten modules into the control panel. Each module has illuminated symbol showing the effect it will produce. Slide an effect out—slide another in—it's just that easy. You get just the right effect to add that extra SELL to your programs and commercials.

**SIMPLIFIED CONTROL**—Push-buttons put effects selection at your fingertips. Push the buttons below the illuminated symbol and you are ready to go "on-air." Wipes and transitions are controlled by a standard fader lever for simple foolproof operation.

**UNLIMITED VARIETY**—The complete complement of 154 special effects includes wipes, split-screens, picture insets, block, wedge, circular and multiple frequency patterns. In addition, the system will accept a keying signal from any camera source to produce a limitless variety of effects—inset letters, drawings, trademarks; self-keyed video insets, and traveling mattes.

**THE BEST EFFECTS WITH LESS EFFORT**—Mix color and black-and-white. Enjoy exceptionally clean transitions . . . the most exciting effects ever conceived! And get them with the least amount of effort possible.

Ask your RCA Broadcast representative for complete information. Or write to RCA, Dept. BN-22, Building 15-1, Camden, N. J. In Canada: RCA VICTOR Company Ltd., Montreal



Tmk(s) ©

# RADIO CORPORATION of AMERICA

BROADCAST AND TELEVISION EQUIPMENT, CAMDEN, N. J.

Vol. No. 105

September, 1959

# BROADCAST NEWS

*published by*

**RADIO CORPORATION OF AMERICA**  
BROADCAST & TELEVISION EQUIPMENT DIVISION  
CAMDEN, NEW JERSEY

*issued quarterly*

**PRICE** *in U.S.A. - - - - \$4.00 for 4 issues*  
*outside U.S.A. - - - \$5.00 for 4 issues*

## CONTENTS

	Page
COLOR BASEBALL TELECASTING . . . . .	6
SATELLITES EXTEND CANADIAN TV . . . . .	13
WIBG COMPLETELY MODERNIZES TRANSMITTER FACILITIES . . . . .	16
WONA—A STREAMLINED, EFFICIENT RADIO STATION . . . . .	22
CONSIDERATIONS IN OBTAINING QUADRATURE ALIGNMENT IN TV TAPE RECORDERS . . . . .	26
TV TAPE BOLSTERS WISN SPORTS SCHEDULE . . . . .	30
FIRST TV TAPE SEMINAR . . . . .	31
WBAL-TV INSTALLS TV TAPE . . . . .	34
LOWRY AFB EMPLOYS CC-TV FOR TECHNICAL TRAINING . . . . .	36
NEW 25-KW HIGH-BAND TV TRANSMITTER . . . . .	42
PORTABLE ENVELOPE-DELAY MEASURING EQUIPMENT . . . . .	46
PATTERN SYNTHESIS . . . . .	50
LATEST TRENDS IN TV ANTENNAS . . . . .	56

TT-25CL, 25-Kw Low-Band Transmitter

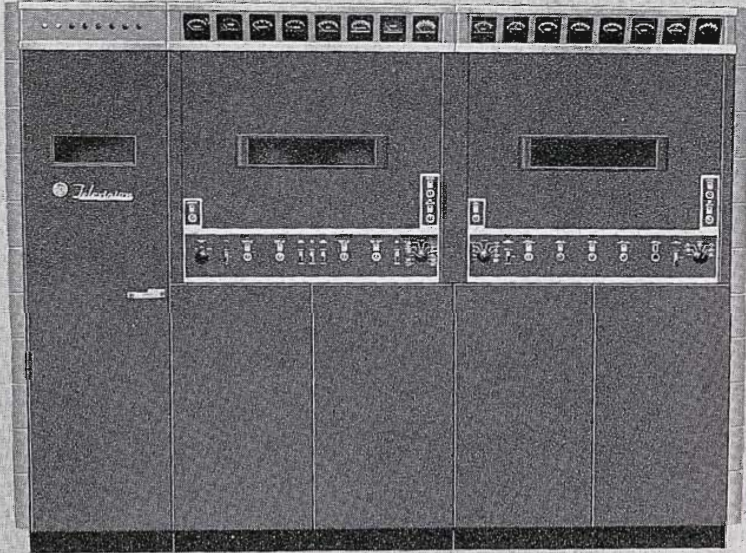
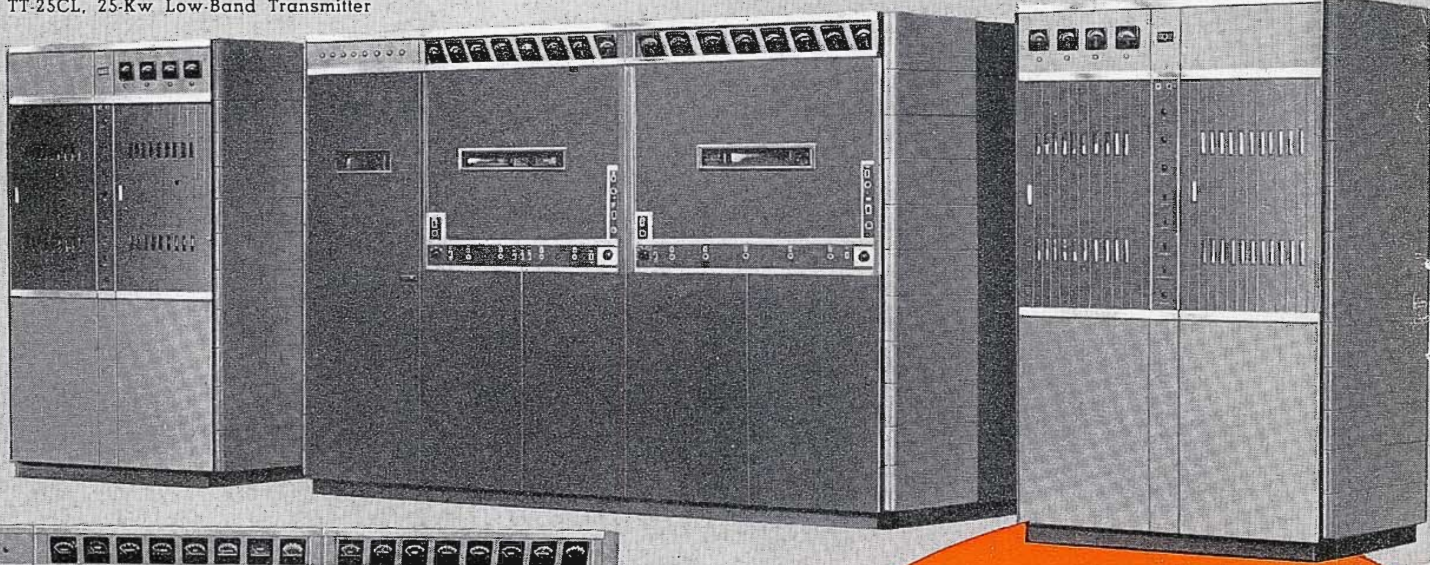

TT-6AL, 6-Kw Low-Band Transmitter

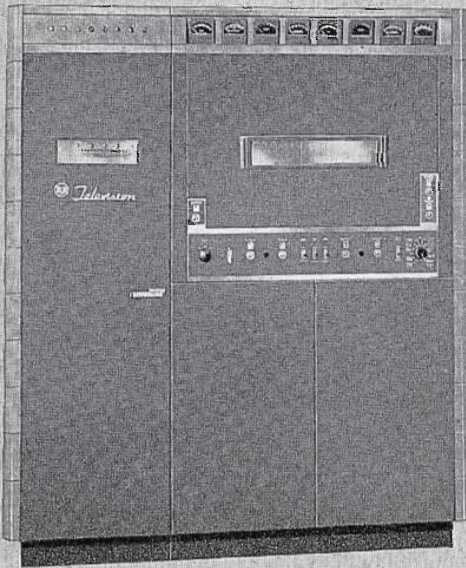

TT-2BL, 2-Kw Low-Band Transmitter

TTL-500AL/AH, 500-Watt Low Power Transmitter

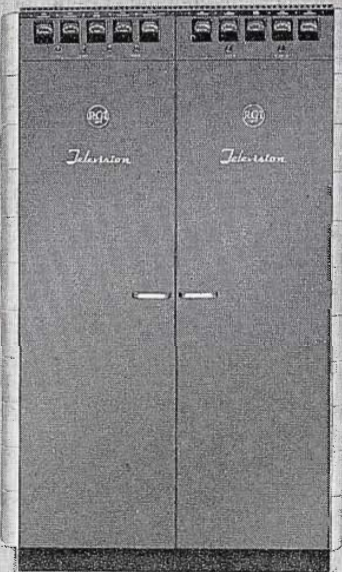

TTL-100AL/AH, 100-Watt Low Power Transmitter

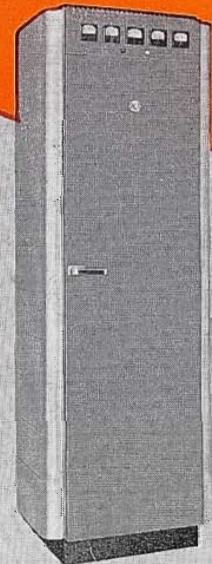

**Television Transmitters with the RCA reputation for Quality**

**ERP's from 100 to 5,000,000 Watts**

ANOTHER WAY RCA  
SERVES INDUSTRY  
THROUGH  
ELECTRONICS

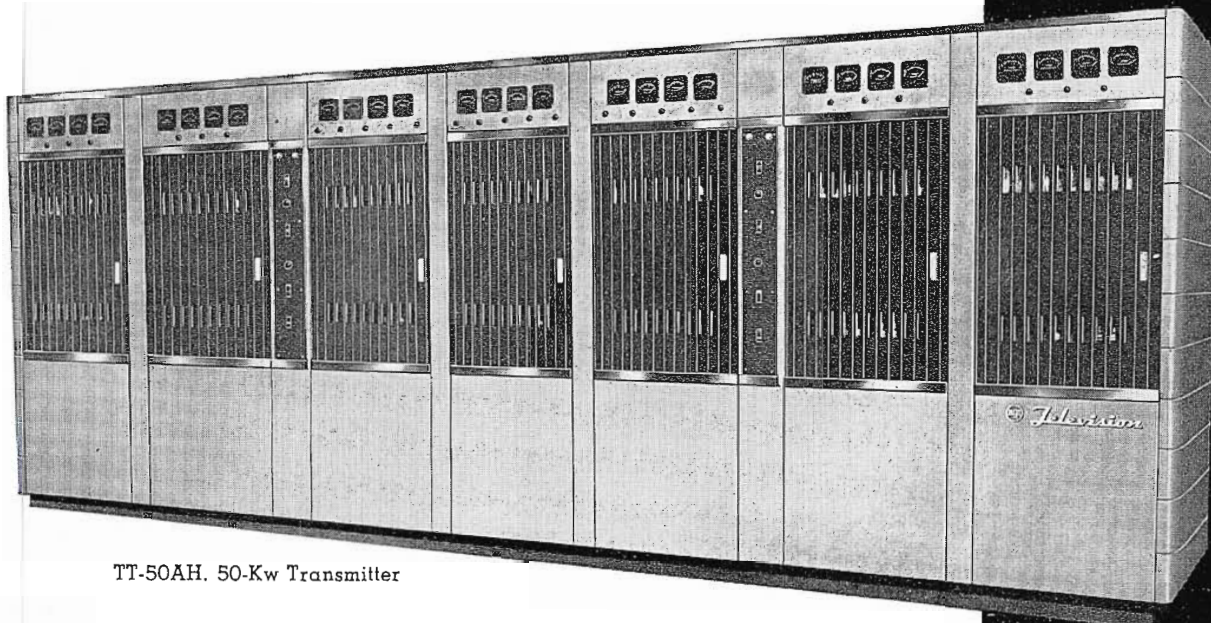

TT-50AH. 50-Kw Transmitter

Since 1929, RCA has designed and manufactured broadcast transmitters. Today, RCA offers this 30 years' experience in providing the most complete line of television transmitters ever built. Included are over 20 different TV transmitters for VHF or UHF application, at any ERP.

If you invest in an RCA television transmitter now, it will assure savings in maintenance and operating costs throughout its lifetime. Even after years of reliable operation it will still have high resale value. Since all RCA TV transmitters are now designed for color as well as monochrome, they are ready for color when you are. And most of them have provision for remote control, in anticipation of future requirements. Consider these additional advantages:

1. RCA Transmitters are generally less expensive to operate. This is true because in almost every power class RCA Transmitters use less power and have lower tube costs.
2. All are designed for color as well as monochrome.
3. All use standard tubes—easily obtainable, economical and dependable.
4. All offer excellent accessibility, reasonable installation costs; all operating controls are accessible from front panel.
5. Most use new aural and visual TV exciter to minimize intercarrier subcarrier beat during color transmission.
6. Many have built-in provisions for proposed remote control of TV transmitters.
7. In most cases, lower power units can serve as efficient drivers when you go to higher power.
8. RCA Transmitters almost always have better resale value.

*For complete information about these quality transmitters, call your nearest RCA Representative. He will be glad to give you the benefit of his (and RCA's) equipment knowledge. There's no obligation. For further particulars, write to RCA, Dept. Y-361, Building 15-1, Camden, N. J. In Canada: RCA VICTOR Company Limited, Montreal.*

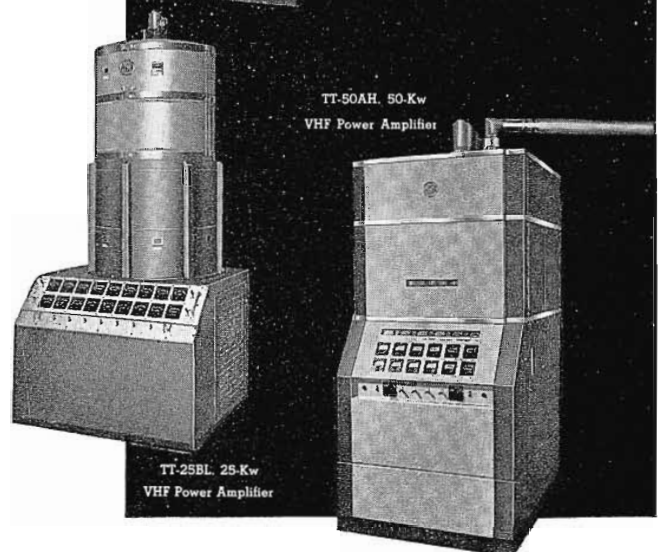

TT-50AH. 50-Kw  
VHF Power Amplifier

TT-25BL. 25-Kw  
VHF Power Amplifier



Tmk(s) ©

**RADIO CORPORATION of AMERICA**

BROADCAST AND TELEVISION EQUIPMENT  
CAMDEN, N. J.

# "Traveling

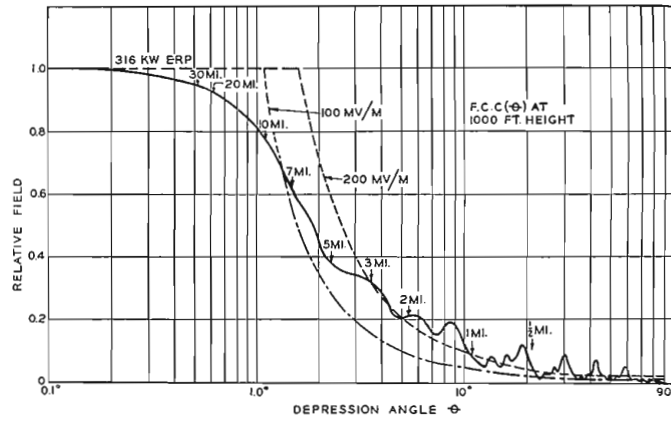
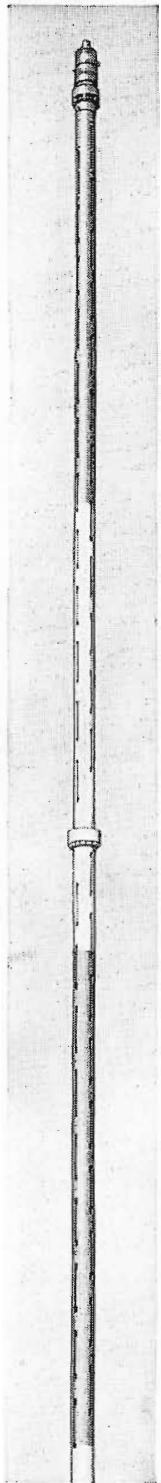

## CHANNEL 10

GAIN OF 18 ANTENNA PATTERN  
(CALCULATED)

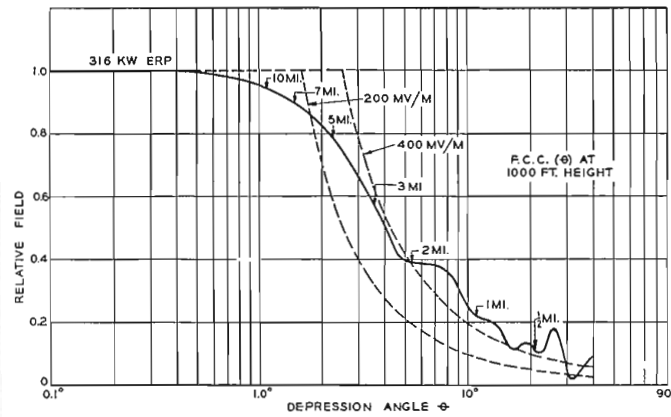

## CHANNEL 7

GAIN OF 8 ANTENNA PATTERN  
(MEASURED)

FOR HIGH-BAND  
VHF OMNIDIRECTIONAL  
SERVICE

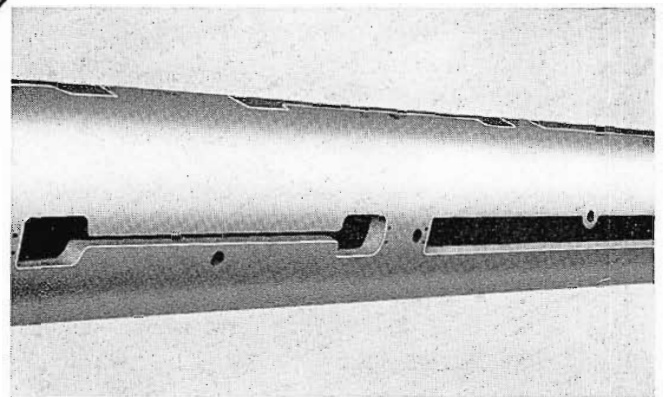

CLOSE-UP OF ANTENNA SHOWING  
UNIQUE SLOT RADIATOR DESIGN



**RADIO**

Tmk(s) ®



# Wave" Antenna

**Combines Improved Electrical Characteristics  
with Mechanical Simplicity and Economy . . .  
for High Power TV Applications**

Here is a VHF high-band antenna that has an inherently low VSWR and produces better patterns. A new design, based on slot radiators, results in improved circularity. This new antenna also features low wind resistance and better weather protection.

## **INHERENTLY LOW VSWR**

The traveling-wave nature of the feed results in a low VSWR along the antenna. This characteristic inherently gives the antenna a good input VSWR without any compensating or matching devices. The input tee has been broad-banded to provide a smooth transition from the transmission line to the antenna.

## **ALMOST IDEAL VERTICAL PATTERN**

A vertical pattern is obtained which is an extremely smooth null-less pattern—see accompanying patterns. This provides the service area at most locations with a uniformly high field strength. Gains from approx. 6 to 20 at VHF high band can be obtained.

## **IMPROVED CIRCULARITY**

The individual patterns produced by slot radiators when added in phase quadrature result in an over-all pattern with improved circularity. In addition, there are no external elements in the field. This design combines radiating elements, feed system and antenna structure in one unit, giving excellent horizontal circularity.

## **LOW WIND RESISTANCE**

### **AND WEATHER PROTECTION**

The smooth cylindrical shape of the antenna is ideal for reducing wind load and has high structural strength. It is designed to withstand a wind pressure of 50 psf on flats, or  $33\frac{1}{2}$  on cylindrical surfaces. In addition, the absence of protruding elements minimizes the danger of ice damage. The steel outer conductor is hot-dip galvanized for better conductivity and protection. The inner conductor of the antenna is rigidly supported at the bottom end without having to rely on any insulator type of support to carry the dead weight. The pole is designed for tower mounting with a buried section extending into the tower. The pole socket carries the dead weight of the antenna. Polyethylene slot covers are fastened to the pole over every slot.

## **SIMPLIFIED FEED SYSTEM**

The feed system is completely inside the antenna, hence any effects on the pattern have been eliminated. The feed system is a simplified one consisting of a large coax line and coupling probes.

*The RCA "Traveling Wave" Antenna can provide you with the answer to your need for a VHF High Band Antenna which combines mechanical simplicity and economy, especially in high-gain, high-power applications. Your RCA Broadcast Representative will gladly help with TV antenna planning. See him for details on this new antenna. In Canada: RCA VICTOR Company Limited, Montreal.*

**C O R P O R A T I O N   o f   A M E R I C A**

**BROADCAST AND TELEVISION EQUIPMENT • Camden, N. J.**

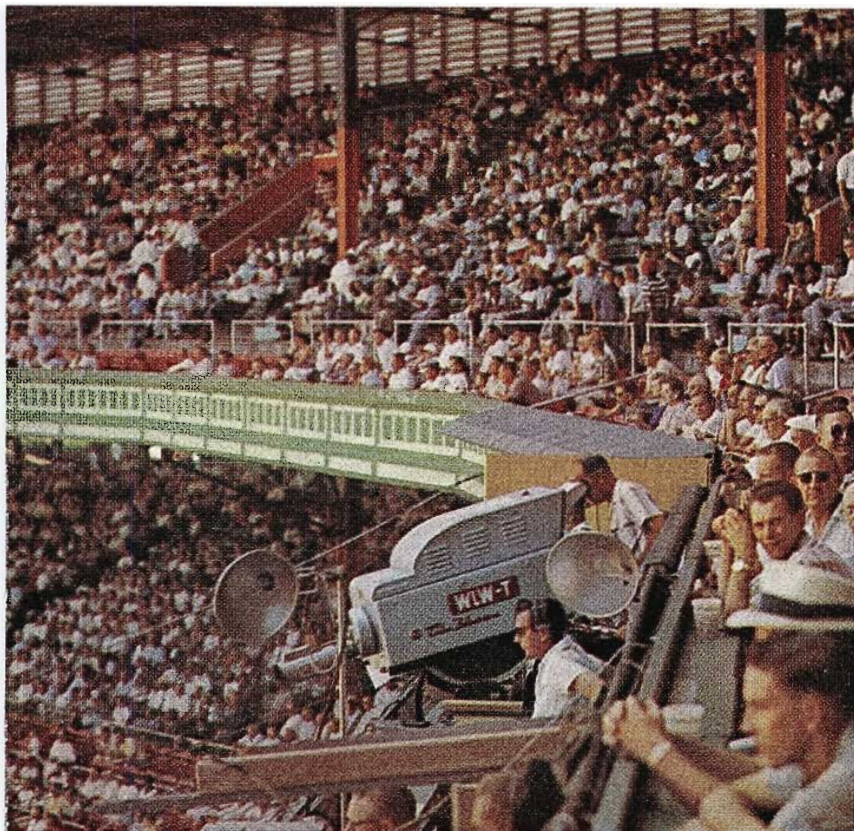

FIG. 1. Located in the tv booth behind home plate, an RCA color camera does double duty—picking up infield action as well as live commercial inserts and between-inning commentary by station sportscasters.

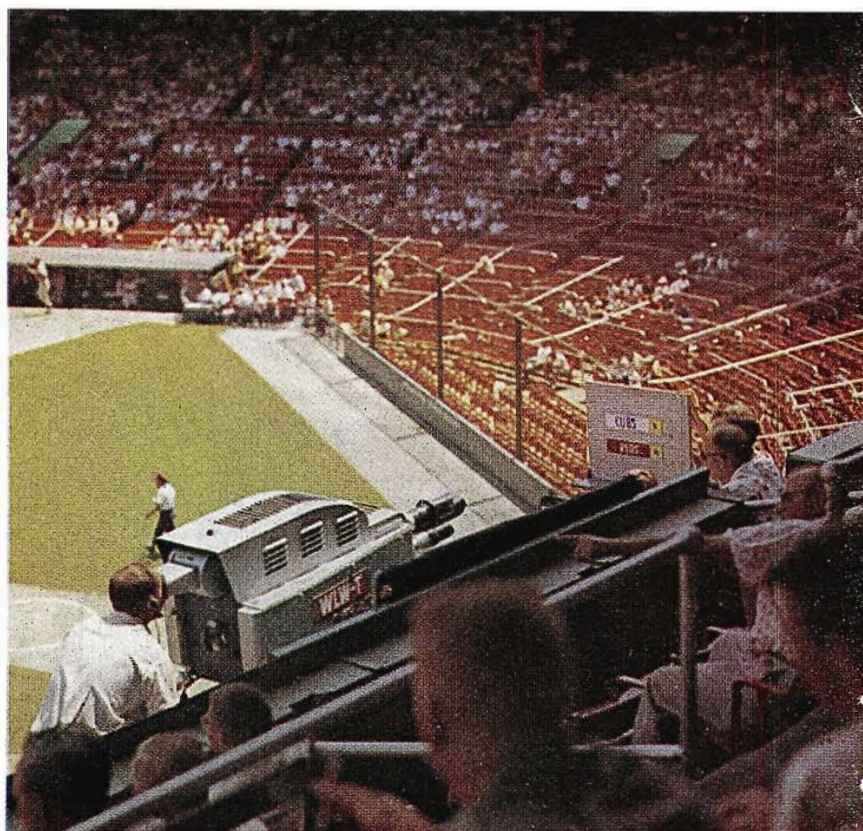

FIG. 2. Another multi-purpose color camera is located in a tv booth at third base. It performs a variety of assignments in both infield and outfield, and also picks up titles, such as running score.

# color baseball telecasting

**WLW-T Coverage of Redlegs' Home Games Increases**

**Color Set Sales, Ballpark Attendance, and Station Viewing**



FIG. 3. The WLW Color Television Mobile Unit is parked just outside of Crosley Field. About 500 feet of camera cable connect each of the color cameras to their respective control positions located within the unit. The video switcher and audio console are also located in the unit.

Major league baseball, telecast for the first time in color on a local and regional basis, has sparkplugged Crosley stations' summer color promotion plans. Part of a Crosley program to advance the progress of color telecasting in the Cincinnati, Columbus, Dayton and Indianapolis areas, the baseball colorcasts have promoted marked increases in set sales, park attendance and number of viewers.

Set sales have climbed in the areas served by WLW-T, WLW-C, WLW-D and WLW-I to an estimated 30,000 total. Fan's support of the Redlegs, as reflected in ballpark attendance, has been remarkably good, despite the club's poor showing earlier in the season. In addition fans who can't get out to the games stay glued to color sets in homes, taverns and other public places, giving a boost to station color ratings.

## 12 Home Games Colorcast

A total of 12 Saturday and Sunday afternoon homegames of the Cincinnati Redlegs were televised in color using the facilities of WLW-T's RCA equipped color tv mobile unit. All twelve of the games were carried over a regional network consisting of WLW-T, Cincinnati, WLW-D, Dayton, and WLEX-TV, Lexington. In addition, ten of the games were also carried on WLW-C, Columbus, and WSAZ-TV, Huntington.



### Three Camera Coverage of Games

All three of the station's TK-41 Color Cameras are used for television coverage of the games. These are stationed in the tv booths located directly behind first base, third base and home plate. From here tv cameramen get a vista of the game's action.

Two of the cameras double in brass. While used primarily to spotlight action in the infield, the homeplate camera also serves to pick up live commercial inserts as well as between-inning commentary by sportscasters George Bryson and Frank McCormick. The third base camera has a variety of assignments in both infield and outfield. In addition it is called upon to pick up titles—such as the running score to be superimposed on the action.

### Mobile Control Room

About 500 feet of camera cable connect each of the color cameras with the color mobile unit—parked just outside the ballpark. This serves as a mobile control room for all of the station's color operations. The forward section of the "control room" contains operating control equipment for the three color cameras, the video switcher, and audio console. It is temperature controlled by a three-ton air conditioner and heating elements.

The rear section houses distribution, terminal and test equipment. This area is also utilized for storage of spare parts and tubes, cameras and mounting equipment. Cables for cameras, microphones and power are stored beneath the unit. The power supplies, a-c power control circuits, isolation transformer and automatic voltage-regulating equipments are located at the extreme rear of the unit.

The control room is manned by two video operators, an audio/video switching operator, a program director and program commercial co-ordinator. They handle all technical and program functions for the colorcast. The program is fed via cable to the Crosley Square studio location. From there it is sent out via telephone company facilities to stations on the regional hookup.

### Over 20 Hours Local Color Weekly

The addition of color baseball to WLW-T's growing color schedule—previously averaging  $17\frac{1}{2}$  hours per week—places the weekly average well over 20 hours. This is in addition to the regular schedule of NBC programs carried by the station. Other regularly scheduled local programs include the "Ruth Lyons 50-50 Club," "Midwestern Hayride," "Paul Dixon Show," "Starmaker Revue," and "City Manager Reports."

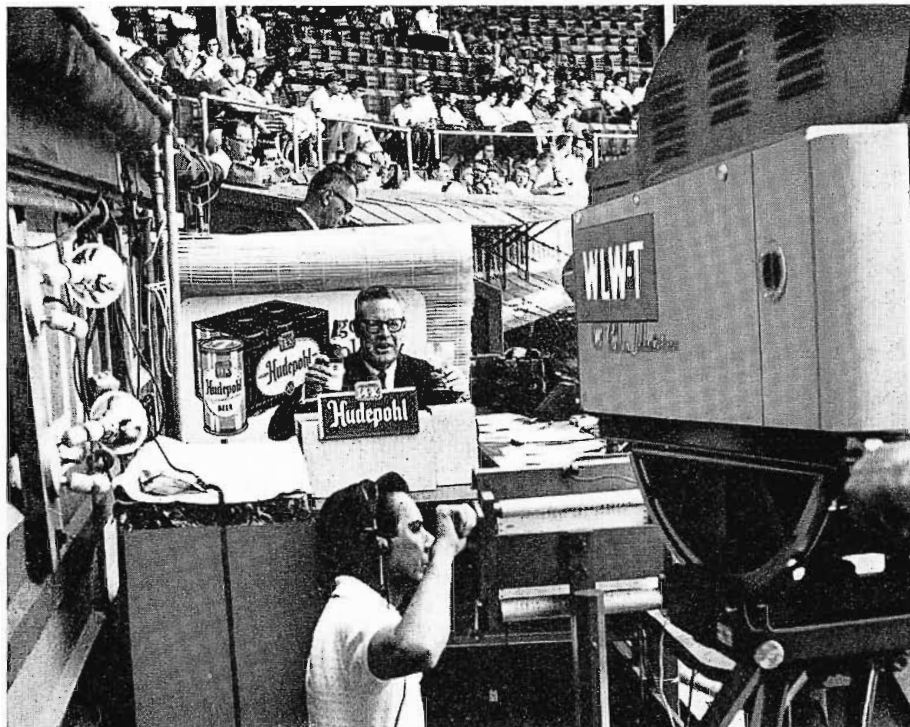

FIG. 4. A miniature set for live commercials is located in the tv booth behind home plate. The color camera is positioned so that it may be easily swung around to pick up the commercials. A portable hand-prompter and two fill-in flood lights complete the equipment complement.



FIG. 5. Inside the mobile unit, two operators handle the controls for the three color cameras. Additional personnel on baseball remotes include an audio/video switching operator, a program director and a program commercial co-ordinator, all of whom sit on a raised platform overlooking the program monitors.

# station promotion helps spur set sales

Crosley stations have spent a great deal of time and money to promote color set sales via color baseball promotions. The campaign has included letters to set owners, RCA dealers, and tavern owners to stir up enthusiasm in color TV. Window streamers were prepared and distributed to set dealers and other public places of business—also color schedules of games, table tents and truck posters. The color-cast of each game was also promoted via

250 cab covers, 500 car cards on Cincinnati buses, and 360 car cards for buses in surrounding areas. "Be-sure-to-see-the-game-in-color" advertisements were placed in *TV Guide* and in Cincinnati, Dayton and Columbus newspapers; promotional announcements and clip sheets were also sent to these newspapers.

A heavy schedule of on-air promotion announcements were made on WLW-T, WLW-D, WLW-C and WLW-Radio. In

FIG. 6. Samples of promotional materials prepared for color baseball campaign include car cards, cab covers, posters, ads, game schedules, and mailers. Color slides accompanied by on-air announcements were heavily scheduled.

**DIRECT FROM CROSLY FIELD**  
**BASEBALL IN COLOR**  
**WLW-T**  
**CH. 5**

**REDS VS CHICAGO CUBS**  
**SAT. AUG. 1**  
**SUN. AUG. 2**  
**1:25 P.M.**

**SEE THE REDS PLAY IN COLOR**

**SEE REDS BASEBALL IN COLOR**  
**ON RCA VICTOR COLOR TV**  
**HERE** **SAT., JULY 11**  
**REDS vs SAN FRANCISCO**  
 Sponsored by **HUDEPOHL and SOHIO**

**wlv television** now brings you **Baseball in Color** (also black and white)  
**Today — 1:25 P. M.**  
 Cincinnati Reds vs. Pittsburgh Pirates at Crosley Field  
 with sportscasters, George Bryson (l) and Frank McCormick (r) giving the play-by-play.  
**CHANNEL 2 DAYTON** **CHANNEL 5 CINCINNATI**

**1959 BASEBALL SCHEDULE CINCINNATI REDS GAMES TELEVISED ON WLW-T • WLW-D • WLW-C**

HOME GAMES	AWAY GAMES
C April 9—Pittsburgh	C April 10—Philadelphia
C April 15—Pittsburgh	C April 11—Philadelphia
C April 18—Philadelphia	C April 17—Philadelphia
C April 25—Milwaukee	F May 1—Milwaukee
C April 26—Chicago	C May 9—Milwaukee
F April 20—Chicago	C May 10—Milwaukee
C May 4—San Francisco	F May 14—Chicago
F May 27—Philadelphia	F May 22—Pittsburgh
May 20—Pittsburgh	C May 23—Pittsburgh
F June 7—Los Angeles	C May 24—Pittsburgh
F June 8—San Francisco	May 12—St. Louis
C June 23—Chicago	F June 13—St. Louis
C June 27—St. Louis	C June 14—St. Louis
C June 11—San Francisco	June 21—Los Angeles
C July 17—Los Angeles	July 4—Pittsburgh
July 25—Philadelphia	July 5—Pittsburgh
C July 30—St. Louis	C July 10—Chicago
C Aug. 1—Chicago	C July 23—Milwaukee
C Aug. 7—Chicago	F July 25—San Francisco
F Aug. 13—Milwaukee	C Aug. 9—Philadelphia
F Aug. 17—San Francisco	Aug. 15—Philadelphia
F Aug. 27—St. Louis	Aug. 16—Philadelphia
C Sept. 5—Milwaukee	F Aug. 19—St. Louis
Sept. 26—Pittsburgh	F Aug. 20—St. Louis
	Aug. 11—Milwaukee
	F Sept. 12—Milwaukee
	C Sept. 13—Milwaukee
	Sept. 19—Pittsburgh
	Sept. 20—Pittsburgh

**BASEBALL SATURDAY!**  
**IN COLOR**  
 Direct from Crosley Field  
**1:25 p.m.**  
**CINCINNATI REDS VS SAN FRANCISCO**  
**WLW TELEVISION** **CH. 5**

**Tele-Log** June 1959 **NBC CHANNEL 4**

**SUMMERTIME COLOR-FULL ON 4**  
 Color = Channel 4

addition, window and lobby displays were prepared for each of the stations. In order to encourage public exposure to color games, the stations offered to provide a free spot to all places of business buying a color television set to show the Redleg games.

### RCA Service Company Participation

The local RCA Service Company assisted with the color promotion. Service Company trucks carried signs and posters promoting each of the games to be telecast in color.

In addition, two special color tv contract and antenna offers were prepared. A standard plan offered installation of an antenna and a one year service policy at a combined price of \$99.95. A deluxe plan offered installation of a Color-Sceptor antenna, finished completely in gold, along with a one year service policy for \$129.95. Both of these plans were heavily promoted by the stations, the Service Company, and the local RCA distributor.

### Ohio Appliances Participation

The RCA Victor distributor, Ohio Appliances, ran a special advertising campaign as part of the color promotion. A series of four newspaper ads on a baseball colorcast were placed each week-end. Two of the ads appeared on the sports pages of Friday evening and Saturday morning papers. These were designed to encourage color set sales to business establishments. All public places of business owning and displaying color sets were listed if they chose to be. The other two ads were placed in the television sections of the same papers. Here all dealers who owned and displayed an Anniversary Model color set throughout the entire promotion were listed.

A special "bonus" was offered to each dealer selling a color set to a public place. Ads were run in *TV Guide*. Ohio Appliance became a participating sponsor in each of the baseball colorcasts. Each program featured a full 60-second spot presented in color. In addition a schedule of 10 and 15-second spots were interspersed throughout the game. The spots were directed to viewers of black-and-white sets and extolled the life-like realism and appeal of watching the games in color.

### Financing Plan

The Appliance Buyers Credit Association provided an excellent, low interest plan of financing. The plan calls for no down payment and offers 36 months to pay on a color set, antenna and service



FIG. 7. Special tavern promotion shared largely in the color plan. Sales to taverns were encouraged, streamer and poster kits distributed. Tavern owners reported increased sales when games were colorcast. This owner of a small bar in Reading, Ohio reported an additional \$100 income each time Redlegs' games were aired in color.

package. The plan added considerable promotional impact to the program, since color sets could be advertised as costing the consumer "less than one dollar a day, including installation and service."

### Special Tavern Promotion

It will be remembered that tavern promotions played an important part in the development of black-and-white television. Customers flocked into the taverns to see telecasts of major sporting events. Tavern and TV set sales increased as more and more people were exposed to the wonders of tv. These early successes led Crosley to launch a special tavern promotion for the baseball colorcast. It followed the same formula: major sporting event leading to increased public exposure—this time to color television.

Special mailings were sent to tavern owners in the area pointing out the increased business that would result from installing color sets. Poster and streamer kits were supplied to purchasers of color

sets, the taverns were listed in weekly newspaper ads, and a free spot was given by the tv station in that locality. Emergency tv service was also provided for those taverns with color sets so that the public would be sure to see the best possible color picture at game time.

Results were gratifying. More and more color sets went into taverns. Public exposure to color increased. Taverns large and small reported added business. Many owners found that the color sets were paying for themselves. For example the owner of a small tavern in Reading, Ohio reported his color set accounted for an extra \$100 each time the Redlegs games were aired in color.

Accounts of results such as this were mailed to tavern owners and distributed to dealers throughout the area. Other places of business found results encouraging. Soon the Crosley plan to increase public exposure to color tv was on the move. With continued promotion, this exposure is still growing.



FIG. 8. As soon as the day's studio color schedule is completed, engineers make color equipment ready for baseball telecasts. Here a color camera is dismantled prior to moving it to the mobile unit.



FIG. 9. Camera cables leading to the mobile color control room parked outside Crosley Square Studios are disconnected and coiled. About 500 feet of these cables are required for each camera when used at the ballpark.

## color mobile unit adaptable to studio & remote programs

Designed for completely flexible operations, the RCA color mobile unit serves as a self-contained mobile control room for studio or remote applications. The unit provides a completely compatible extension of the station's regular control facilities. It can be patched into master control, studio control, or, when desired, taken out for use on remote pickups.

For regular studio operations, the three color cameras are used in the WLW-T "Studio A" and are connected by 225 feet of camera cable to their respective control units in the mobile unit, parked adjacent to the studio building. In a little less than two hours the studio setup can be dismantled, cameras transported to the mobile unit, cables disconnected and the complete color facility made ready to drive to the ballpark.

Photos on these pages show the steps which must be taken to prepare for the colorcasts of the ball games. As soon as the color studio is cleared of programming,

the TK-41 color cameras are removed from the studio pedestals so that they may be transported from the fourth floor studio to the color mobile unit. The cameras are strapped to individual dollies—which have been made up by the station. They are moved on these dollies down four flights of stairs with the aid of a specially designed aluminum track. (This is essentially an aluminum ladder to which tracks have been affixed.) This ladder-like device speeds movement down the stairs and into the truck.

Once the cameras have been stored in the mobile unit, all that remains to be done is to disconnect cables from the junction box on the side of the unit. The cable connectors are hung on racks in a weather-proof box permanently mounted to a telephone pole in the parking lot.

Space has been provided in the mobile unit to store all three cameras, tripods and cradle heads, and camera cables for complete remote coverage. Once the unit has

been loaded, it is ready to be driven to the ballpark for setup prior to the game of the day.

Outside Crosley field the color mobile unit occupies its regular parking place. An adjacent telephone pole facilitates running camera and intercom cables into the park. The line to downtown studios is also terminated here. Cameras are removed from the truck and moved into the park much the same as they were taken from the studios. They are setup in the home plate, first and third base TV press boxes. Then, a quick checkout with TV engineers outside and they are ready to go.

This kind of handling is a credit to the stability and performance of TK-41 color cameras and the skill of WLW-T engineers. In a few short hours a complete change in mode of operation is accomplished from studio program to remote pickup. Existing studio operations are discontinued and color facilities made ready for the signal "play ball."



FIG. 10. The three RCA TK-41 Color Cameras are strapped to specially designed dollies to facilitate movement from the fourth-floor studio to the mobile unit parked outside the building. Camera pedestals remain in the studio, as tripods are used at the ballpark.

FIG. 11. The cameras are moved down a single flight of stairs to the alley aided by a specially designed aluminum track. This is essentially an aluminum ladder to which outside tracks are affixed.



FIG. 12. Once the cameras have been stored in place in the mobile unit, cables are disconnected from the junction box on the side of the unit and hung in a weatherproof housing permanently installed on an adjacent pole.



## Crosley Survey Shows That Color Doubles Ratings

What happens when a color television set is purchased? What changes take place in the viewing habits of color set owners and their families? Are they satisfied with their purchase? What are their attitudes toward color programs, color itself, and toward the service they are getting from their color TV sets?

These are questions the Crosley stations wanted answered before launching their "all-out" color promotion. In order to get the answers, they engaged the services of Burke Marketing Research, Inc., of Cincinnati to conduct a *rating survey* of local and network color programs and an *attitude survey* of new purchasers of color sets.

### Ratings Double

The rating survey consisted of 3,192 telephone calls to two separate samples of homes—color TV set owners and black-and-white set owners. The interview simply consisted of determining which, if any, station was being watched and a confirma-

tion that the family was properly classified as to black-and-white or color-TV ownership. The color programs rated twice as high in color tv homes as they did in black and white. Their average rating was 22.7 in black and white homes, and 47.4 in color homes. Average share of audience in color homes was 70.3.

This pattern of ratings, twice as high in color homes, was consistent among all seven programs tested. It was true in the morning (The Paul Dixon show rated 4.2 in black and white homes, 9.3 in color), in the afternoon (Ruth Lyons 50-50 Club rated 16.6 in black and white, 32.5 in color), and in periods of top tune-in such as Sunday night (Dinah Shore rated 34.6 in black and white, 71.5 in color). The black and white programs rated about 40 percent lower in the color homes than in the black and white homes.

Sets-in-use averaged 56.2 in black and white homes, and 67.4 in color homes. The

gain in the ratings for color programs came about half from increased viewing and about half from homes which could have been expected to watch other stations had all programs been in black and white.

### Attitudes Run Good-to-Excellent

The attitude survey was designed to obtain, in greater depth, the opinions and feelings of color set owners. Interviews were conducted with 254 color set families. The number and types of television sets owned was established. Without any prompting, families were asked what they thought of color television, what they liked about it, and what they disliked about it.

The general level of satisfaction with color television was very high. About 85 percent of the respondents gave either *Excellent* or *Good* ratings to the color programs, the quality of the color, and their set performance. Seven out of eight families said that, if they had to do over, they would again buy the color set.

The things liked most about color television were (1) its realism, (2) its beauty, and (3) its increased clarity over black and white. However, there was some discontent with the number of programs available in color.

About three-fourths of the color TV families had at least one black and white set, and one-fourth had at least two black and white sets. Most of the color families were classified by occupation as proprietors, executives, or professional people.

### Color Set Sales Increase

What effect has WLW-T's local color program had on TV sales? Before the programming began, about 6 percent of RCA TV sales in Cincinnati were color sales. Shortly after local color programming started, the figure jumped to 14 percent. Today, 20 percent of RCA sales are color set sales. One out of every five sets sold is a color set! Local color programming helped give Color TV a sales increase of over 200 percent!

### Faith in Future of Color

Results of the color survey have indicated an excellent future in color for Crosley stations. Consumer attitudes are favorable, color ratings have doubled, the number of color sets is increasing. Crosley stations have taken the initiative to provide and promote local color programming to assure their own future in television.

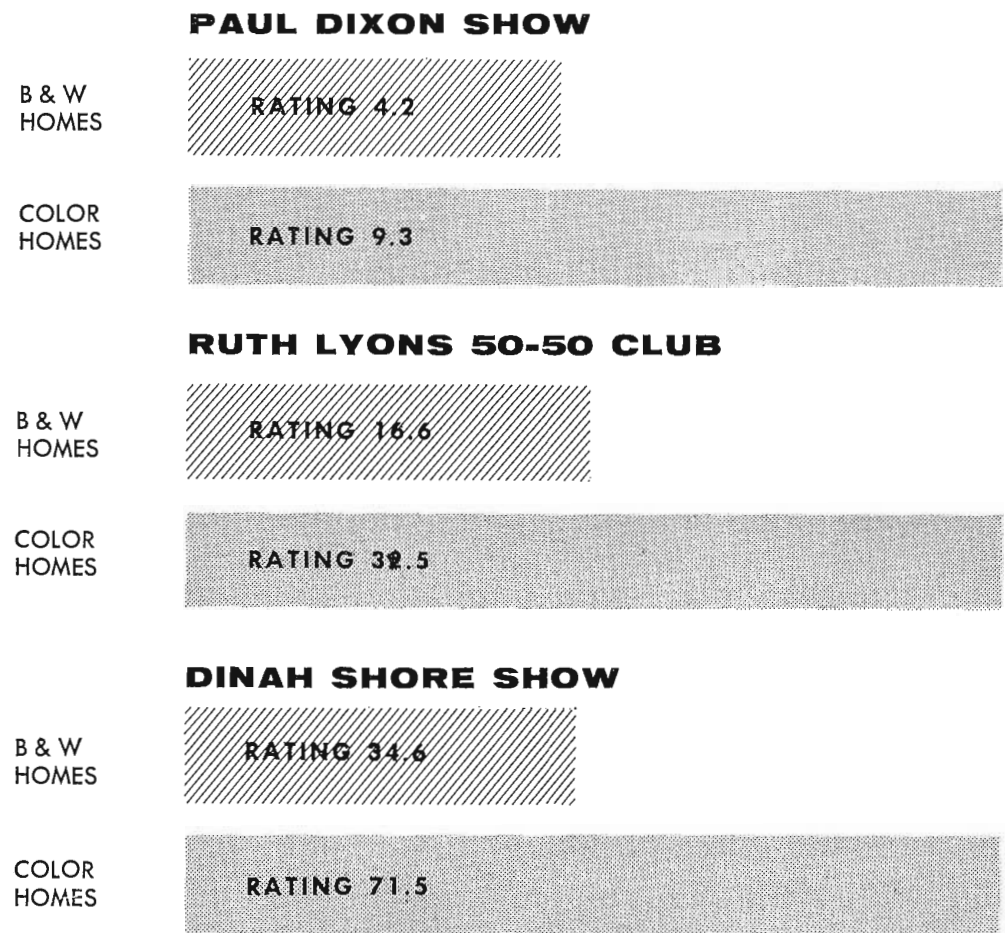

FIG. 13. The pattern of ratings was twice as high in color homes as in black-and-white. This was true throughout the program day—morning, the "Paul Dixon Show"; afternoon, the "Ruth Lyons 50-50 Club"; evening, the "Dinah Shore Show."

# SATELLITES

## Extend Canadian Television Coverage

by B. ROY MACHUM,

Manager, Commercial Marketing, Technical Products

RCA Victor Company, Ltd.

Today approximately 14.5 million Canadians are able to enjoy television by tuning in on one or more of the 43 privately owned stations and the 8 Canadian Broadcasting Corporation stations.

After careful technical evaluation each of these stations has been so located that it serves a concentration of population within a specific area. Through the National Television Network, linking all stations from coast to coast, a program originating in Vancouver may be viewed in almost all parts of the country.

Through the National TV Network, Canada's 50 television stations tie into a 4000 mile electronic program artery extending from Victoria, B. C. to St. John's, Newfoundland. Each station is able to benefit from and contribute to the overall obligation of providing a national program of interest to Canadians in all parts of this vast country.

The growth and development of this dynamic new medium of communications has been remarkable when one considers that only seven years ago not a single Canadian television station was in exist-

ence. Since that time over \$75,000,000 has been invested in equipment and facilities which today provides employment and new creative opportunity to over 10,000 Canadians.

In recent years much consideration has been given to the problems of providing television to the 2.5 million Canadians in numerous widely scattered communities, who are not within the reception range of existing stations.

The complexity of television as compared to standard radio broadcasting, and the line-of-sight limitation of the transmitted signal, has reduced this problem of providing rural coverage to one of simple economics. An inexpensive method of extending the coverage of existing stations by means of small unattended slave or "satellite" stations seemed to be the only practical solution.

Early in 1955 engineers of RCA Victor in Montreal embarked on an extensive design and development program to provide an equipment to meet this challenge that would develop with the growth of Canadian television (see Fig. 1).

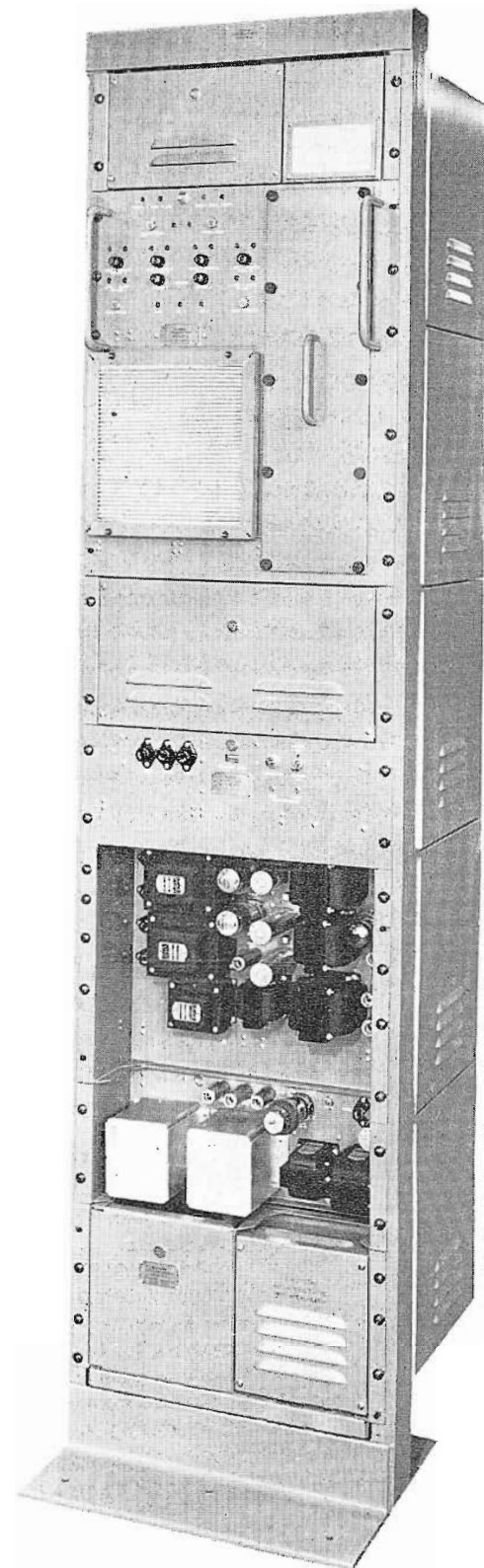

FIG. 1. The TVR-1 television satellite relay equipment designed by engineers of RCA Victor Company, Ltd., Montreal, to meet the needs of TV broadcasters desirous of extending their services to fringe or isolated areas.

The following basic requirements were considered in the design and development of equipment for Television Satellite Operation:

- (a) Must be of simple conventional design to enable routine maintenance by semi-skilled personnel without the necessity for expensive specialized test equipment.
- (b) Must be designed for completely unattended operation.
- (c) Must be extremely reliable to allow operation from relatively inaccessible sites with minimum of maintenance and attention.
- (d) Must be small physically and low in power consumption.
- (e) Must be capable of at least 100 watts power output of retransmitted signal.
- (f) The design quality must be such that a signal from the master station may be fed through at least six satellite stations in tandem with no degradation of picture quality.
- (g) Must be lower in cost than any other known method of relaying television signals. (Average cost of electronic

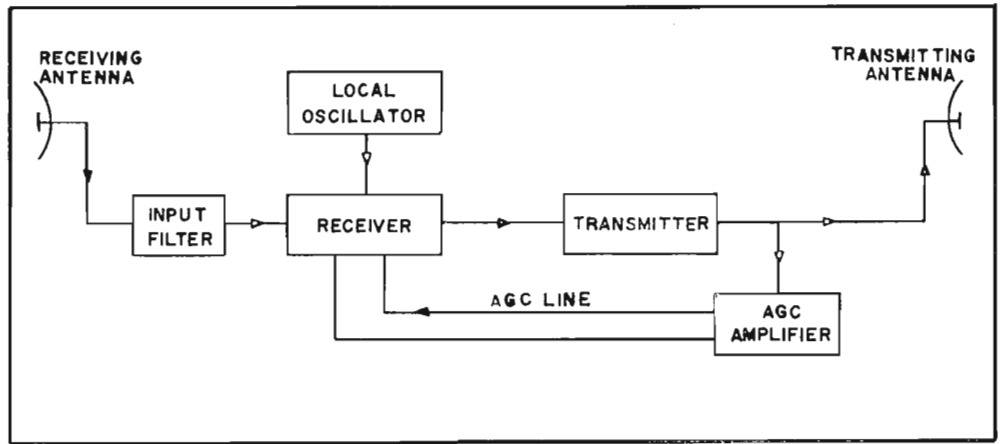

FIG. 2. Block Diagram Television Relay Unit, TVR-1.

equipment, towers, antennas, etc., for typical single satellite station, approximately \$30,000.)

### TVR-1 Satellite System

During 1956, after a concentrated development program and extensive field tests from the RCA Victor, Covey Hill, Quebec test site, a quantity of TVR-1 Satellite equipments were produced in Montreal. This new Canadian television product

more than met the design requirements outlined above.

Basically, the TVR-1 receives the signal from a standard incoming television channel, converts it to another standard channel without demodulation, amplifies and delivers the new channel output to the antenna. Virtually, the TVR-1 satellite system is a Class "A" Linear Amplifier having the input sensibility of a high grade TV receiver, and a power output equivalent to a 100-watt TV Transmitter. The complete television signal with both visual and aural carriers is amplified and relayed by the linear amplifier system. Because of the heterodyne action of the local oscillator, the output carrier signal is automatically removed when the input signal from the master station is cut off. This allows complete control of transmitter signal from the master station. The TVR-1 satellite equipment is normally left with full power on at all times. This method of operation improves the performance reliability and tube life of the equipment (see Fig. 2).

### Existing Canadian Satellite Systems

Television Station CJON-TV in St. John's, Nfld., uses this unique equipment in Canada's first television satellite CJOX-TV, Argentia. Situated on the east coast of the Avalon Peninsula, Argentia was isolated from station CJON-TV due to the rapid fall of the land on which it is located. In order to bring television programs to the people of Argentia, and the U.S. Naval Air Base located there, the management of CJON-TV and Chief Engineer, Mr. Oscar Hierlihy, worked closely with RCA Victor engineers in the initial planning and installation of this station. The successful launching, in early 1957, of this first satellite system has rightfully won for CJON-

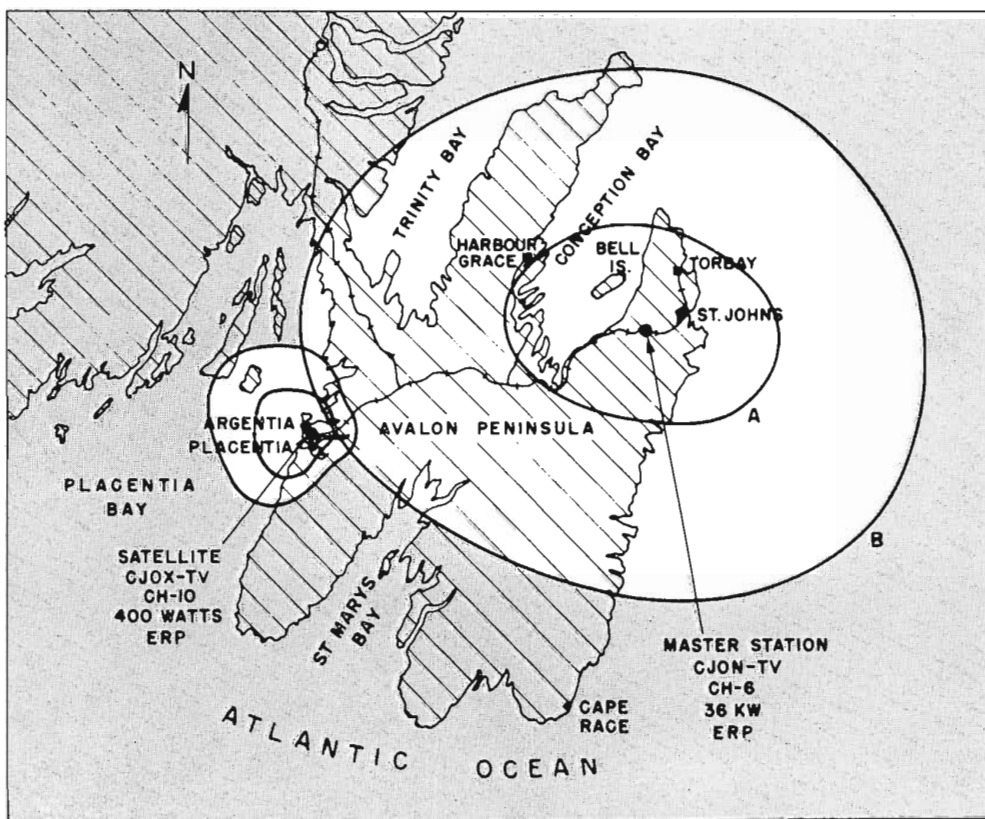

FIG. 3. Sketch of Newfoundland illustrating extension of CJON-TV coverage by single satellite. (Contours as shown are approximate.)



TV the acclaim and admiration of the entire television industry (see Figs. 3 and 4).

This first station at Argentia provided the pattern for engineering design of a number of more complex satellite systems.

Installation of a similar satellite system in the Okanagan Valley of British Columbia followed the Newfoundland project by a few months. This is of particular interest since twin satellite stations are used in the same system. The master station CHBC-TV, Kelowna, is located at the "V" of a double bend in a narrow valley, with the cities of Vernon and Penticton located at the extremities, a difficult situation for satisfactory propagation due to extremely mountainous terrain (see Fig. 5).

The double satellite arrangement solved the problem at nominal cost, and provided good television reception in all these centres.

A third and even more unique application of this equipment was installed by RCA Victor engineers in Nova Scotia. This three-station tandem-fed system demonstrates the flexibility of TVR-1 equipment, and its potential application to providing television in sparsely settled areas. Through these three satellites the Canadian Broad-

casting Corporation master station CBHT-TV at Halifax extends its program service to the Liverpool, Shelbourne, Yarmouth areas of Nova Scotia (see Fig. 6).

Canada's most powerful television satellite has been installed at Elliot Lake, Ontario, by CKSO-TV, Sudbury, some 90 miles away. In this system, a 7000-mc microwave link of 35 miles is involved in relaying programs to the satellite from the master station. The completely RCA equipped master station CKSO-TV, Sudbury, Ontario, inaugurated in 1952, was the first privately owned TV station in Canada. In 1957 the power was increased and the original 2-kw transmitter removed and transferred to Elliot Lake for use as a satellite to serve this remote but fast growing uranium mining community.

There are now ten Satellite TV Stations in Canada. Seven of these were designed and supplied by RCA Victor engineers. With the demand for television service constantly broadening and with electronic achievements diminishing economic barriers, it is reasonable to expect that almost every Canadian home may, in the near future, enjoy the many entertainment, cultural and educational benefits of this remarkable new medium.

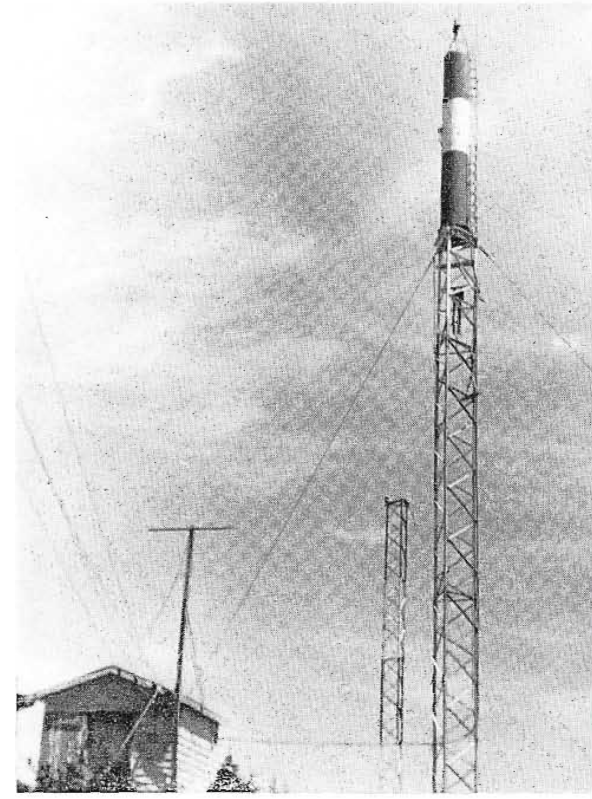

FIG. 4. RCA Victor satellite installation at Argentia. Pioneer station CJON-TV, St. John's, Newfoundland, together with its satellite CJOX-TV, Argentia, comprise the first system of its kind in North America.

FIG. 5. Sketch of Okanagan Valley, Central British Columbia, illustrating use of two satellites to extend coverage of CHBC-TV, otherwise limited by mountainous terrain. (Contours are approximate.)

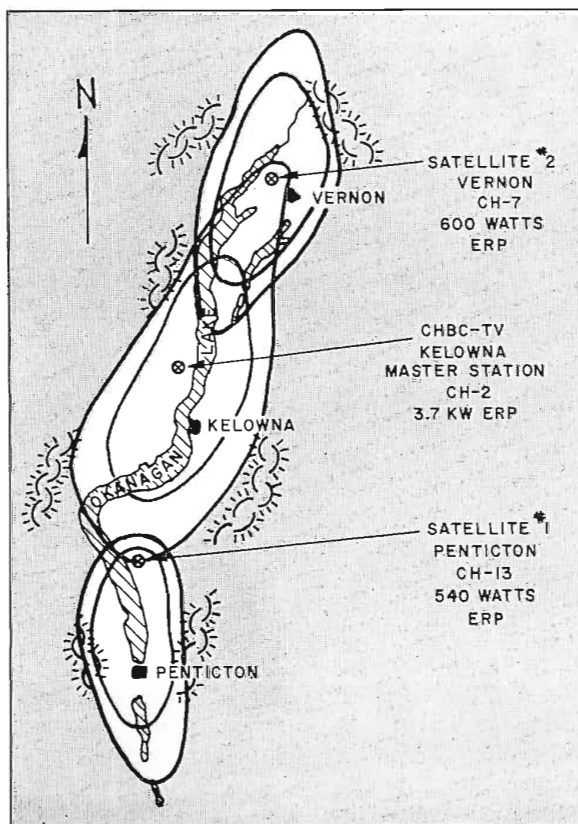
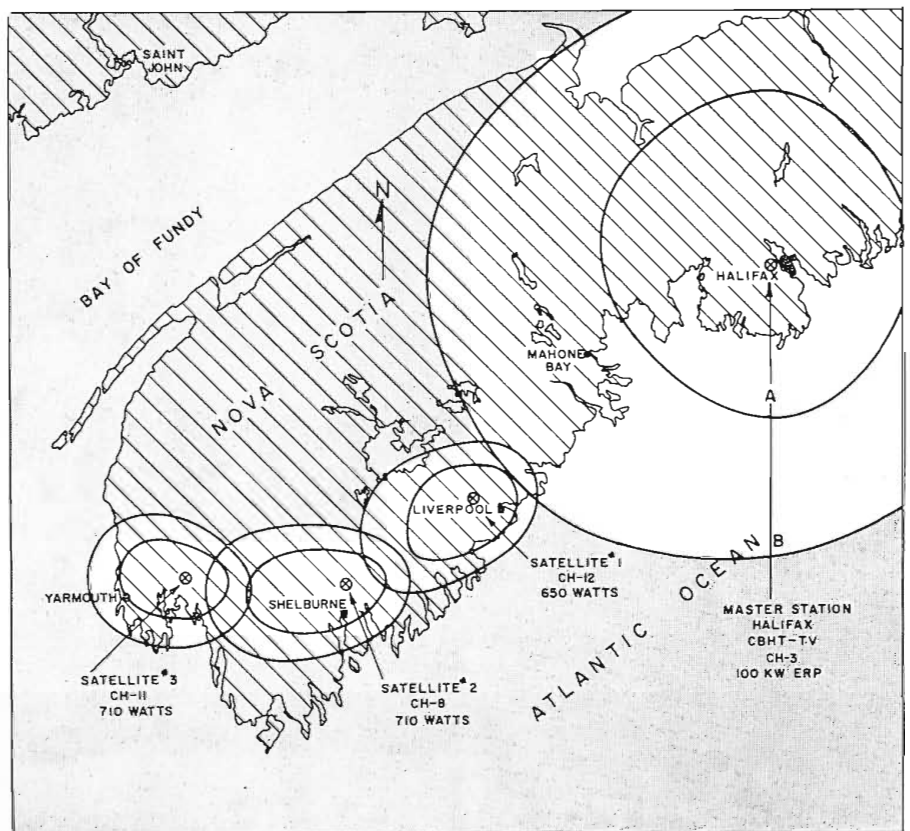

FIG. 6. Sketch of Nova Scotia illustrating extension of CBHT-TV coverage by three tandem satellites. (Contours are approximate only.)





# WIBG COMPLETELY MODERNIZES ITS TRANSMITTER FACILITIES

*Rapid Installation of Three New Transmitters Accomplished  
Without Interruption of Broadcast Schedule*



FIG. 1. WIBG's modern split level building located near Lafayette Hills in suburban Philadelphia shown here. The single story section (on the left) houses the station's offices. The larger section on the right contains the studios, control room, transmitter workshop, and garage.

by JOHN HENNINGER,  
Chief Engineer, WIBG and WIBG-FM

Since May, 1957, when WIBG became a Storer Broadcasting Company station, it has been steadily improving both facilities and ratings. A Storer type of programming was introduced to the Philadelphia area, featuring popular music format with emphasis on local events. Now with a full 50,000 watts, WIBG has not only improved its coverage and facilities, but has become one of the most popular stations in the city.

### Rapid Installation

The entire installation of three new transmitters, new phasing equipment and transmission lines for five towers, and a specially designed and constructed FM isolation coil was accomplished in less than six months—without interruption of the

broadcasting schedule—and with only the normal complement of personnel. In October 1958, WIBG began to install the 50-kw Ampliphase Transmitter, and in April a new 10-kw BTA-10H Transmitter was installed. Finally, in June of 1959, the installation was completed by installing a new 5-kw FM Transmitter, Type BTF-5B. However, during this nine month period, only six months were actually spent installing equipment.

### Modern Facilities

Transmitters, studios, and operating offices of WIBG are in a modern split-level building in suburban Philadelphia. Originally constructed as a two-story transmitter-studio building, WIBG soon found the need to expand its office facilities. These were added to the existing transmitter building to form a split-level structure (see Fig. 1).

The transmitter plant and studios are located on the second floor of the original section of the building (see Fig. 2). All three transmitters are in the single master control room, which faces the three studios. (It is interesting to note that the area now housing a 50-kw and a 10-kw AM transmitter plus a 5-kw FM transmitter was formerly used to house only a 10-kw and a standby 1-kw AM transmitter.) Below the transmitters, on the ground level, two special phasing and distribution equipment rooms have been built to house the 50- and 10-kw phasing and branching equipment. There is also a garage, workshop, and storage space on the ground level. One stall of the garage contains the station's auxiliary diesel generator. This will keep the BTA-10H 10-kw transmitter, studio equipment, and station lighting operating in case of commercial power failure.

### Ampliphase Installation

After considering the various 50-kw transmitters now available, it was apparent that only the BTA-50G Transmitter could be physically housed in the existing facilities at WIBG. Another equally important factor in the selection of the Ampliphase Transmitter was that it could be installed without interruption of WIBG's service.

The BTA-50G is installed on the right hand wall of the control room. The transmitter is flush with the wall, fluorescent lights are mounted overhead (see Fig. 3). Switch gear is accessible through two doors, and is mounted on the walls at the rear of the transmitter. Adequate space is available at the rear of the transmitter to perform necessary maintenance (see Fig. 4). Heavy power distribution and voltage regulating transformers are mounted close to the floor, thus eliminating the need for reinforcing the wall. This helped cut installation time as well as costs.

Complete front and rear accessibility of the BTA-50G makes maintenance easier. Since the ampliphase transmitter is used only for daytime operation, normal maintenance can be performed early in the evening without inconvenience to the engineers.

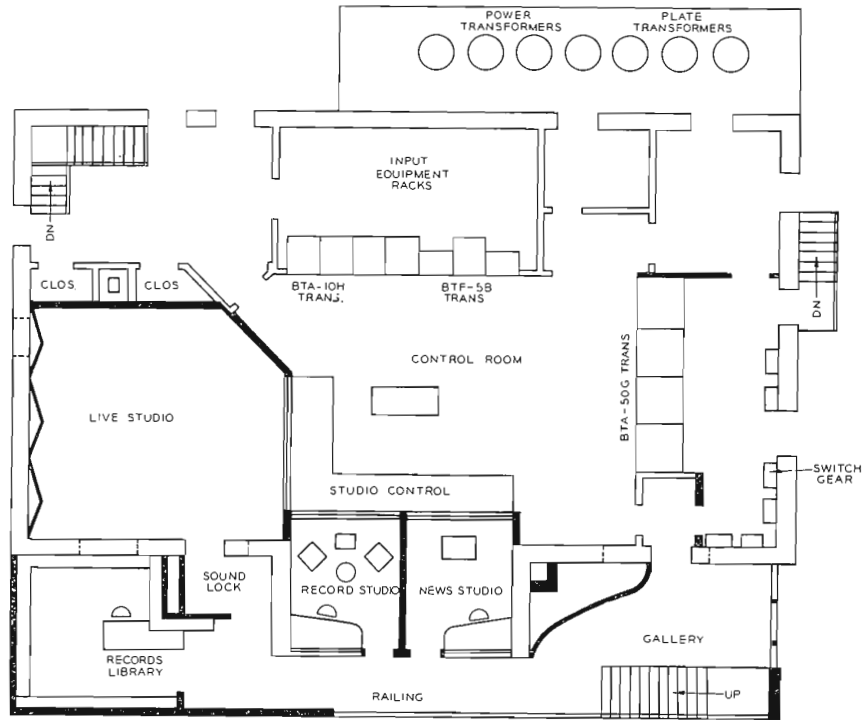

FIG. 2. All operating equipment is located in the large master control room. The three new transmitters are mounted along the walls at the side and rear of the room. Studio control positions are in front of each window with speech input equipment placed to the rear of the operating positions.

FIG. 3. John Henninger, Chief Engineer of WIBG, at the Ampliphase 50-kw transmitter. The 15-foot wide transmitter has been mounted flush with the wall to produce an attractive easy to maintain installation.

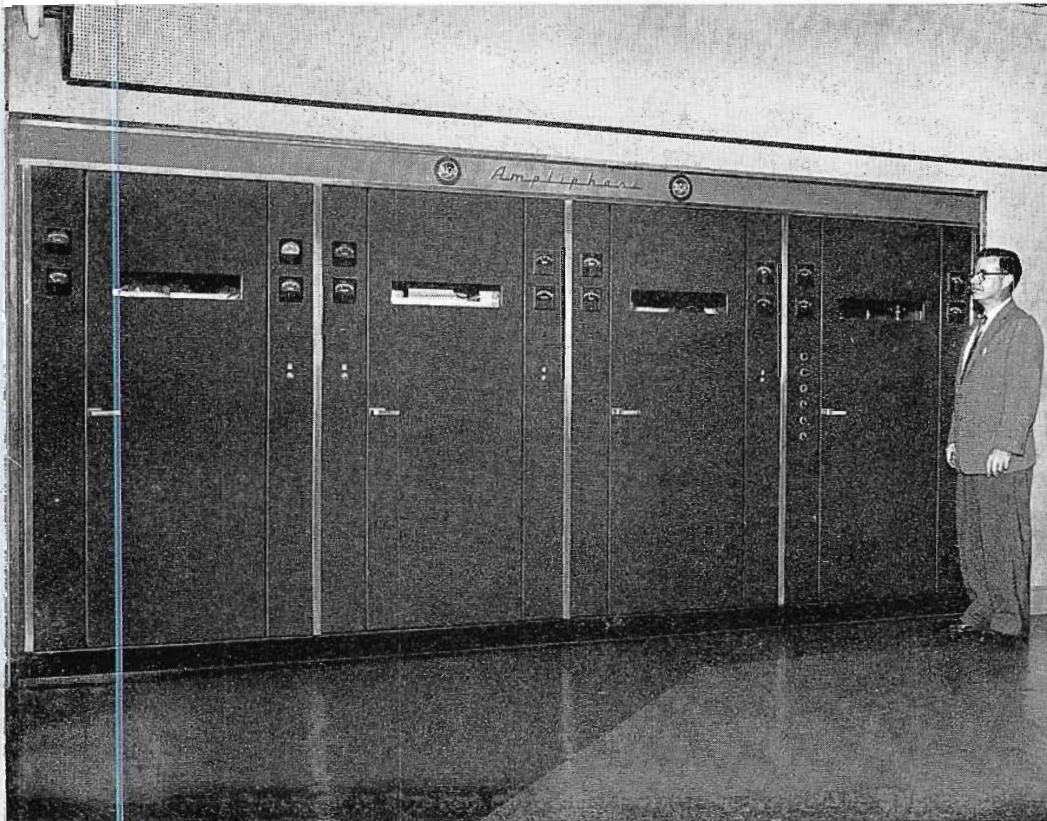
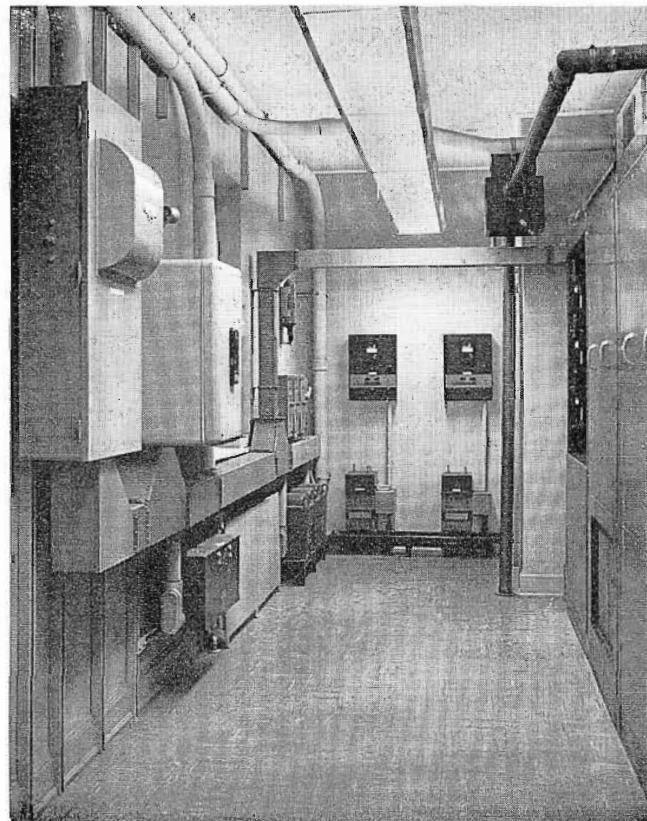

FIG. 4. Rear of the BTA-50G Transmitter. Note the ample access space provided for servicing the transmitter. The switch gear is conveniently mounted along the walls; and heavy distribution transformers on a floor supported platform. Mounting the transformers this way eliminated the need for reinforcing the walls.



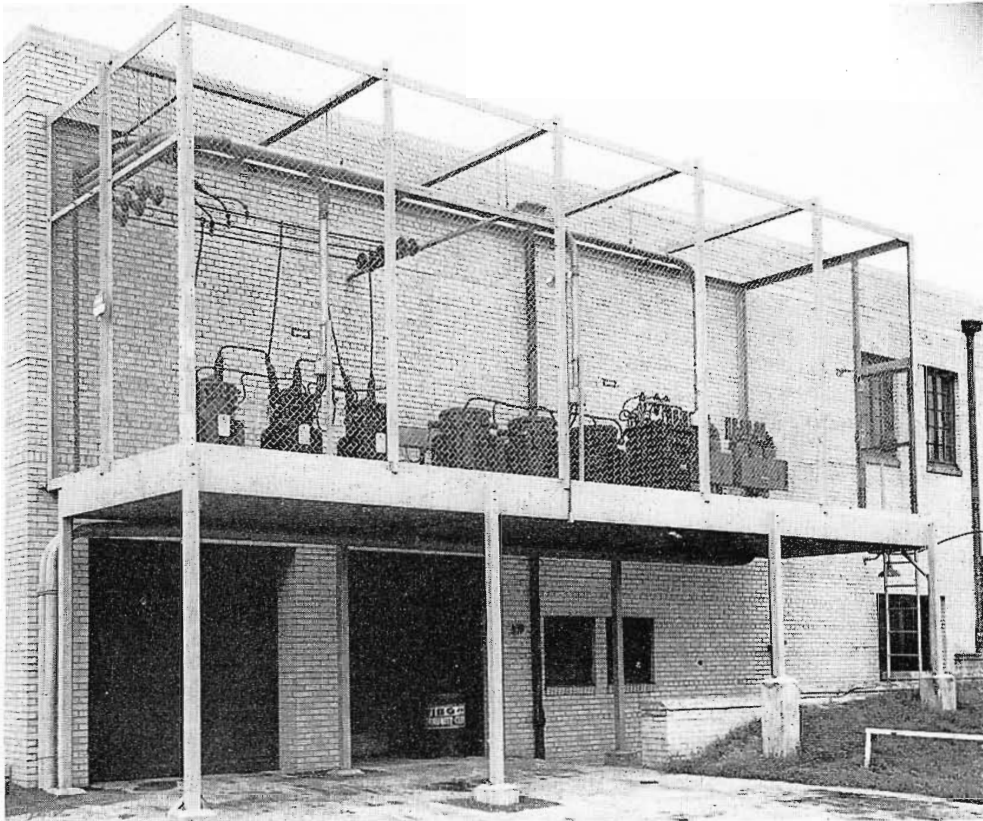

FIG. 5. All station power transformers are mounted on this platform on the side of the building. The three transformers on the left supply 440 volts to the Ampliphase transmitter.

### Power Equipment

Three 440-volt transformers for the BTA-50G Transmitter are mounted on the right side of the platform outside the WIBG building (see Fig. 5). The other transformers on this platform supply power for the BTA-10H and BTF-5B transmitters. For safety, the platform is completely fenced.

Below the steel platform is a two-car garage, one side of which houses the station's emergency diesel generator (see Fig. 6). This generator is capable of supplying enough power to operate the BTA-50G Transmitter at 10-kw or to operate the BTA-10H at full power; in addition, it supplies power to keep station lighting and studio equipment operating during an emergency. A large muffler was installed on the generator to reduce engine noise, and to prevent its being picked-up in the studios.

### Low Power Cost

After increasing power from 10 kw to 50 kw (400 per cent), a large increase in power costs would normally be expected; however, power costs have only increased 45 per cent. The Ampliphase Transmitter

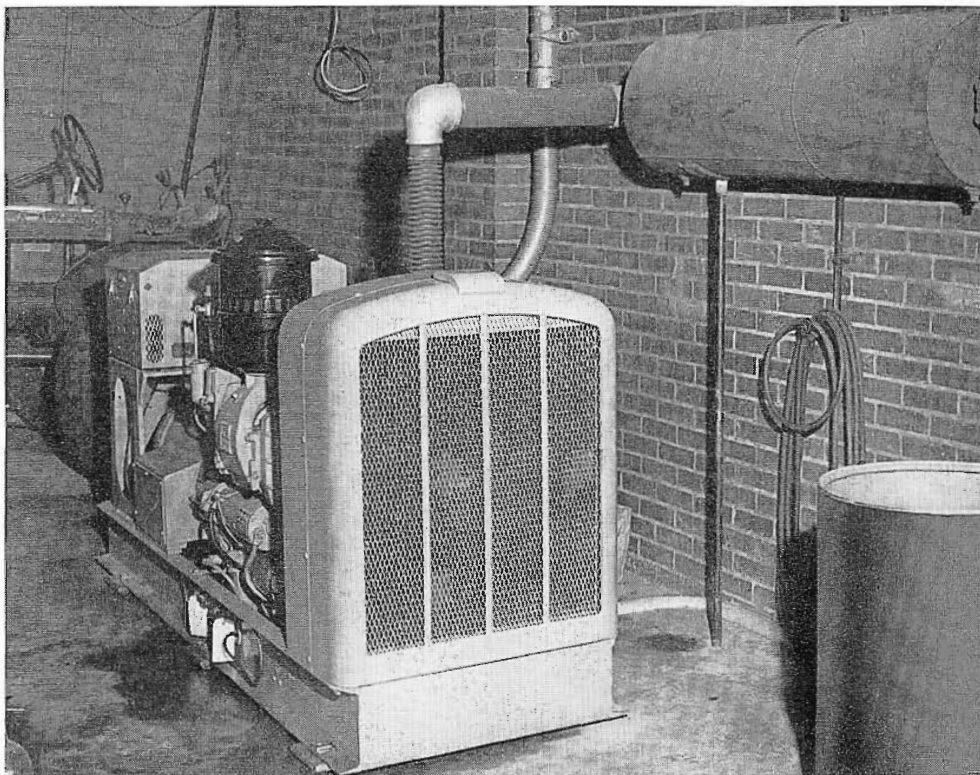

FIG. 6. Emergency power, sufficient to operate either AM Transmitter at full 10 kw output, is supplied by diesel generator, located in the garage below master control room. A large muffler keeps the generator noise level as low as possible.

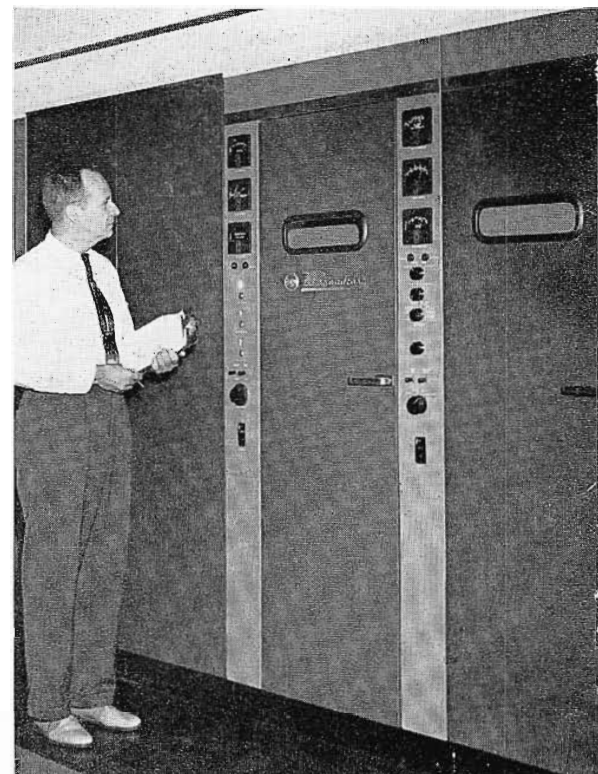

FIG. 7. The BTF-5B FM Transmitter is mounted along the rear wall of the control room. Lester Sacks is shown taking meter reading.

offers true power economy while delivering an excellent signal.

#### Built-In Cooling

All three transmitters, including the 50-kw Ampliphase, are cooled by internal blowers. No external cooling equipment is required. The BTA-50G has an exhaust duct on top on cubicles to expel warm air as rapidly as possible. The blowers in the Ampliphase Transmitter are mounted on the floor, to reduce vibration. Control room noise level at WIBG is amazingly low, even with all three transmitters operating.

#### FM Transmitter Plant

WIBG is presently duplicating its AM programming on FM with a 20-kw ERP signal. FM coverage is almost as extensive as WIBG's 50-kw AM signal. The new type BTF-5B FM Transmitter is operated at 4.9 kw output to conform to the station's licensed ERP. The FM transmitter is mounted flush with the wall and next to the 10-kw AM transmitter (see Fig. 7). A very large area was provided at the rear of these transmitters and is now used for spare parts storage (see Fig. 8).

If in the future multiplex operation should be desired, the required subcarrier generator can be added to the BTF-5B very easily. No additional changes would be required in either transmitter or antenna systems for multiplex operation. Formerly WIBG had a separate FM transmitter site in another part of Philadelphia, but for reasons of economy the FM installation was combined with the AM.

#### Custom Built Isolation Coil

A special FM isolation coil was designed by the author and built by RCA and American Electronics Company to properly isolate the FM antenna from the AM tower upon which it is mounted. The isolation coil, housed in a small shed (see Fig. 9), is connected across the base of the center AM tower. The coil is made from 1 $\frac{3}{8}$ -inch Styroflex transmission line, wound on a 52-inch form, which is 71 inches high. No operating difficulties have been experienced with this coil since it was installed in June of 1959. Another advantage gained has been minimum variation in phasing and amplitude in the AM antenna system during unfavorable weather conditions.

#### New 10-kw AM Equipment

After the Ampliphase Transmitter was installed, it was decided to install a new BTA-10H 10-kw Transmitter for night operation. Even though Ampliphase had a 10-kw power cut-back kit installed, the

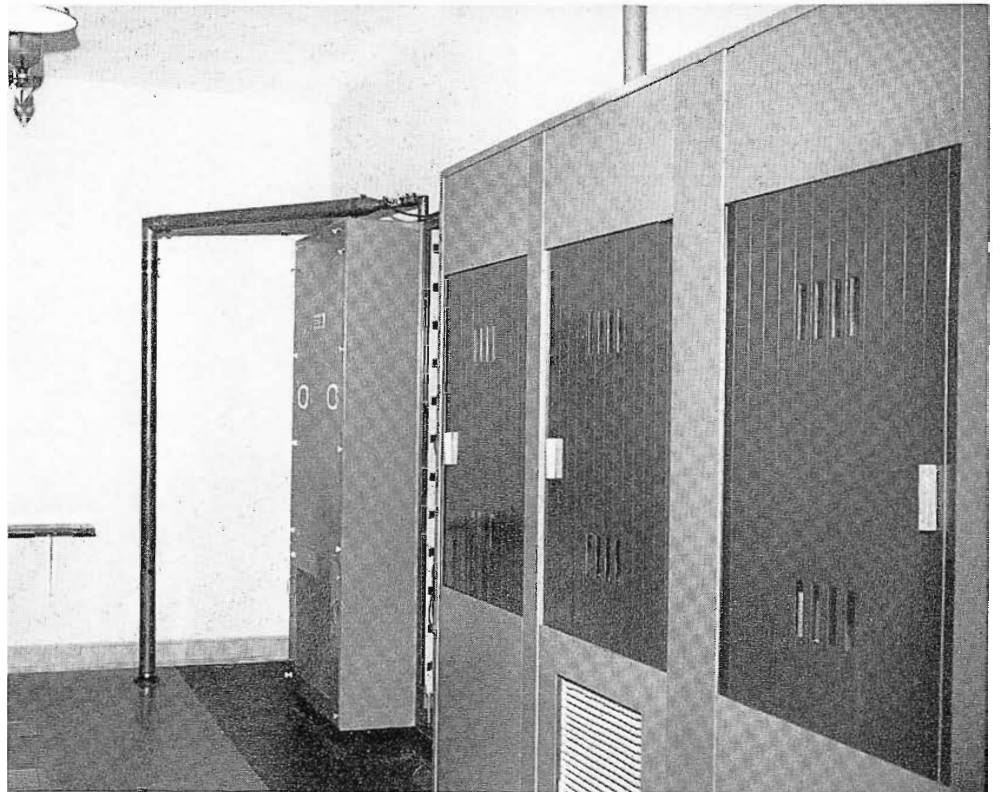

FIG. 8. Extra access space is provided behind the FM transmitter and the BTA-10H. Maintenance is easy and much of the area is used for storage.

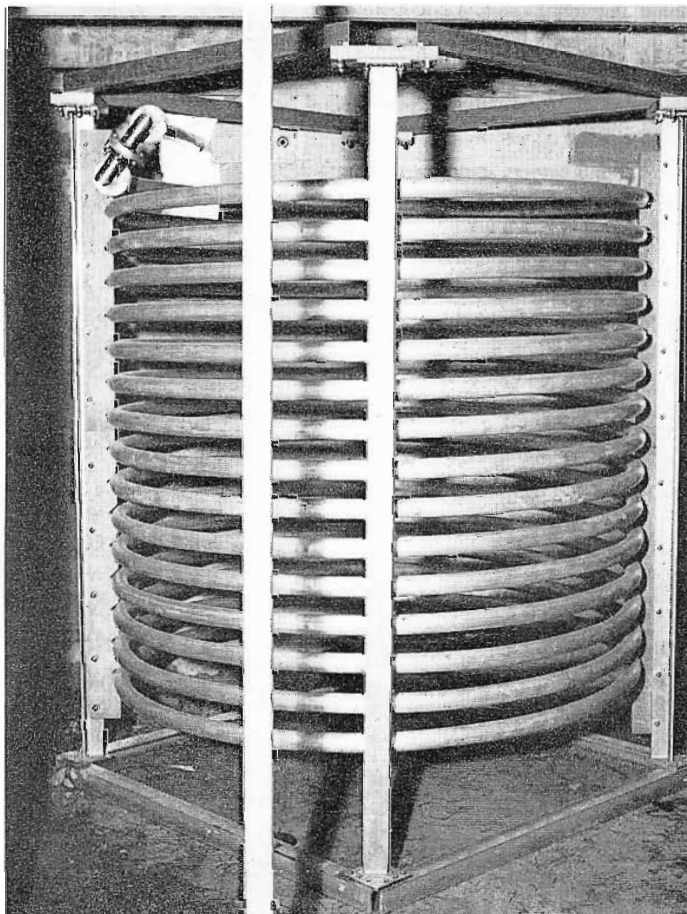
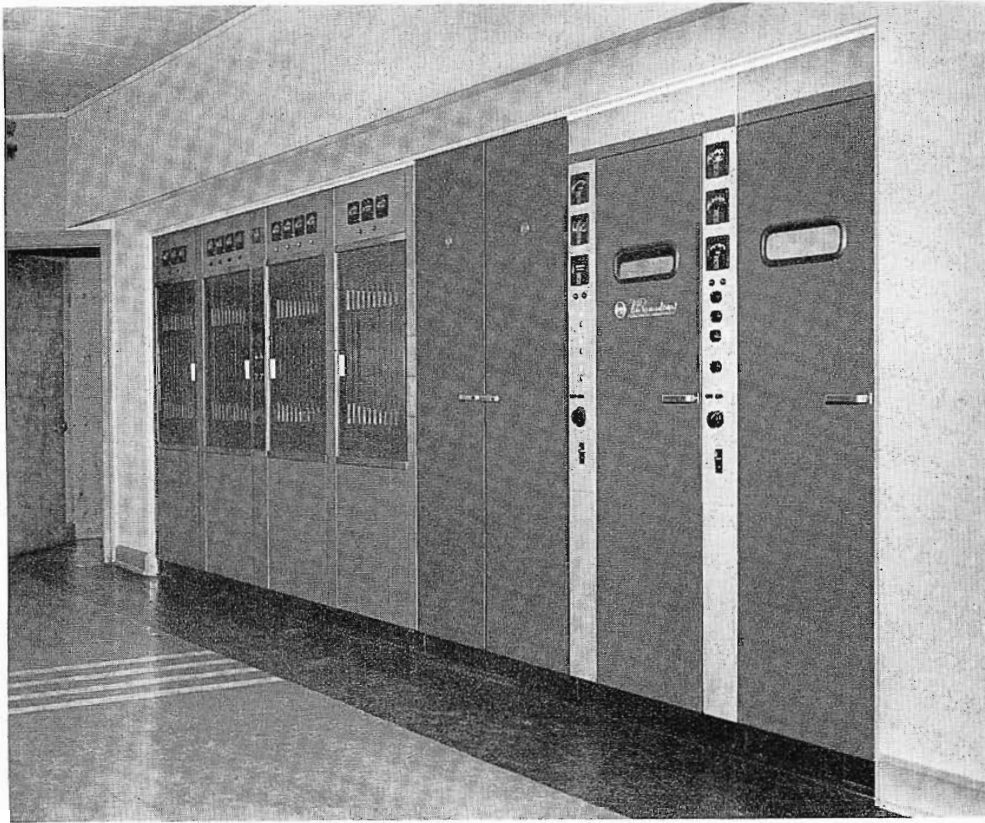

FIG. 9. This is the special FM isolation coil designed by the author. It is mounted in a separate building at the base of the center tower. This 52 by 71 inch coil is made from 1 $\frac{3}{8}$ -inch Styroflex transmission line. The coil isolates the FM signal from the 30 kw AM signal on the tower.



added reliability of a second transmitter was very important. This approach also permits easier maintenance schedules on both transmitters.

Installation of the BTA-10H follows the general plan used on other transmitters. It is placed along the wall with the BTF-5B, with two racks of input equipment between the transmitters (see Fig. 10). The BTA-10H offers more economical operation than the BTA-50G does when operating at 10 kw. Either the BTA-50G or the BTA-10H may be switched into the dummy load. Filaments of the BTA-10H are usually kept on during the day and the output is connected to the dummy load, thus, if difficulties should arise the BTA-10H can be put on-air in a matter of seconds—in either the day or the night pattern.

FIG. 10. The BTA-10H 10-kw Transmitter is mounted along the rear wall with the FM Transmitter and input equipment. This convenient arrangement greatly simplifies operation of all transmitters.

FIG. 11. Five in-line self-supporting towers are used in the WIBG antenna system. Small block houses at the base of each tower contain phasing and distribution equipment. The BFA type FM antenna is side-mounted near the top of the center tower.

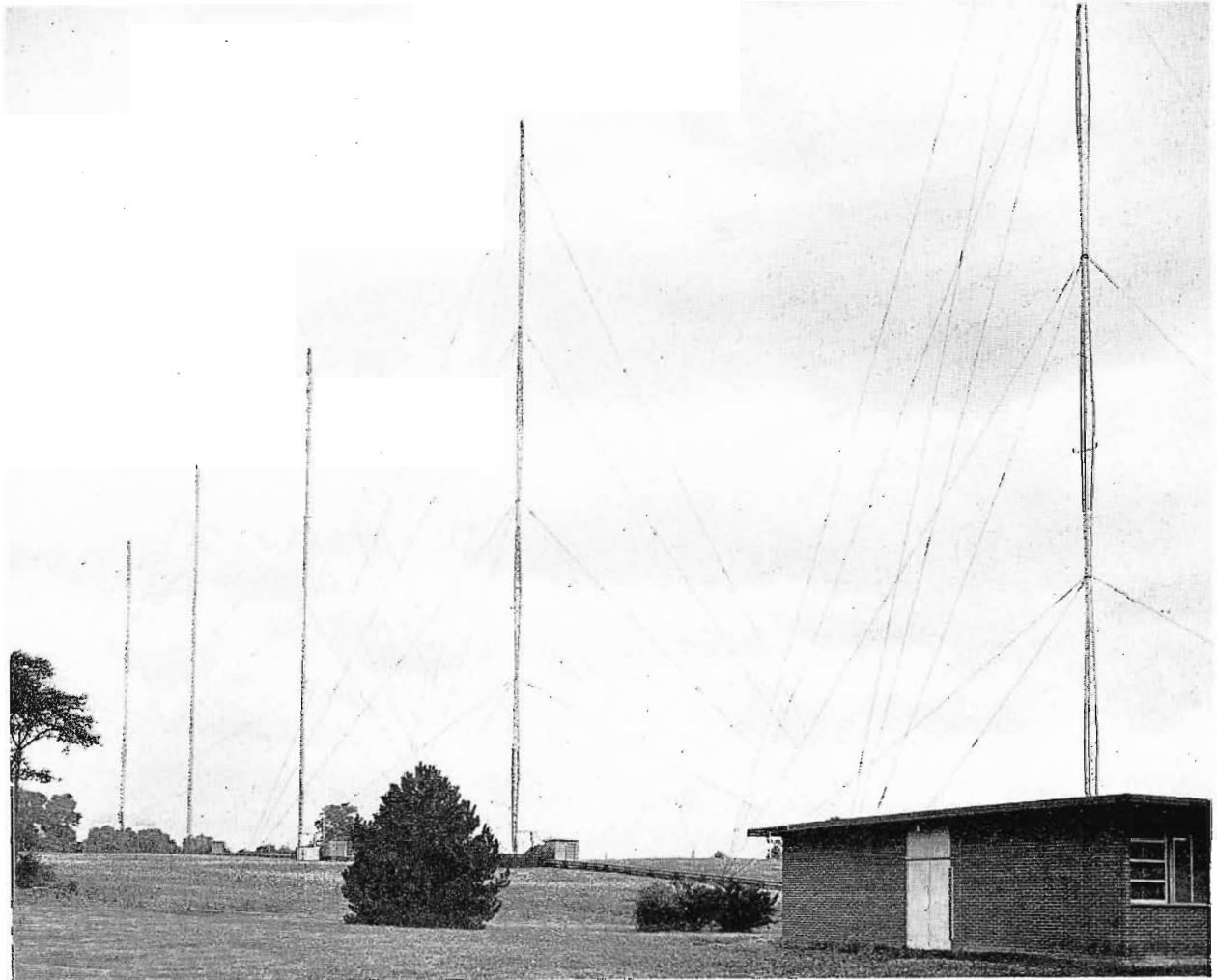

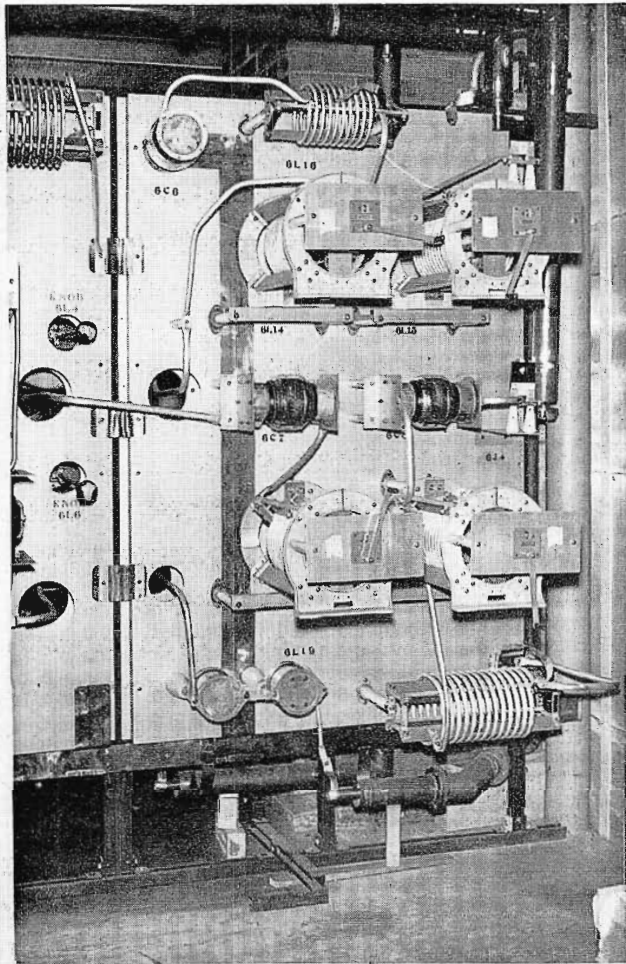

FIG. 12. This is a section of the 50-kw phasing equipment. The room is completely enclosed with copper screening to reduce spurious radiation. Distribution equipment is mounted on the rear of this panel.

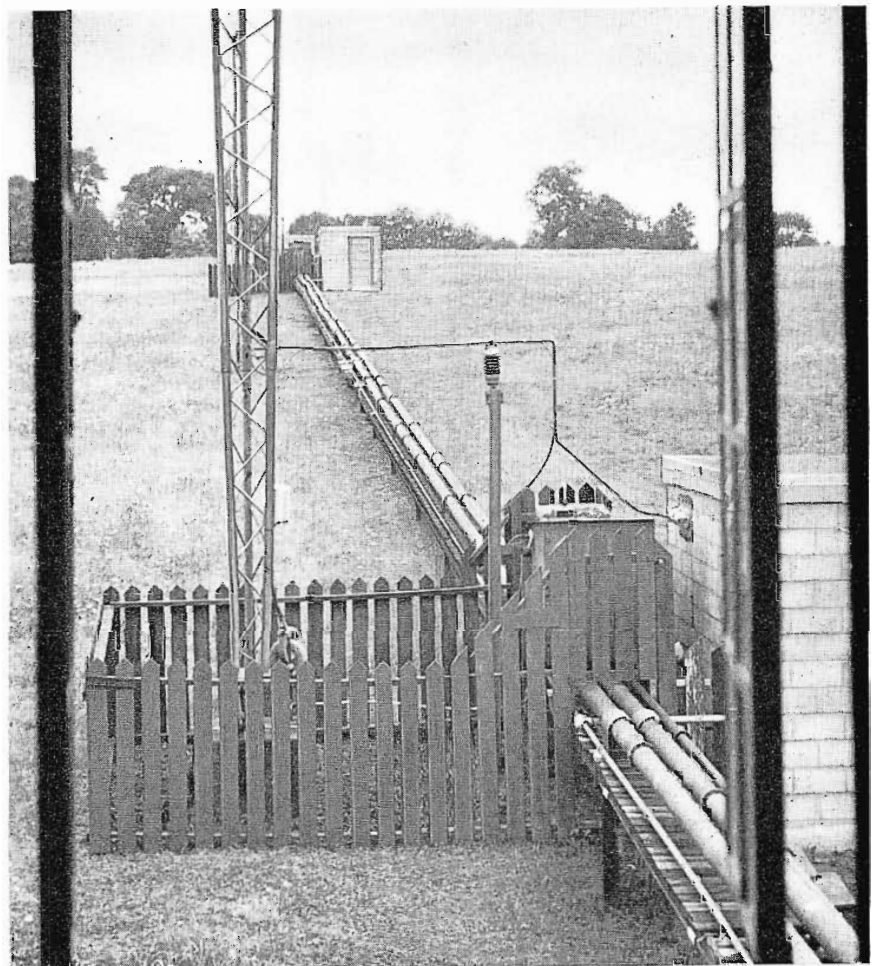

FIG. 13. Duplicate transmission line feeding the WIBG array is run to the towers on a wooden platform. The smaller FM line is shown right.

### Five-Tower Array

Since WIBG's radiation pattern resembles a "U" five in-line towers are required to meet pattern requirements, which protect stations at the Canadian border (see Fig. 11). At the base of each tower phasing equipment is mounted in small brick houses. Separate sets of 10-kw and 50-kw transmission line and distribution equipment have been installed, for extra reliability (see Fig. 12). If trouble develops in one line the other can be switched in immediately, thus preventing lost air time from either line or distribution equipment failures (see Fig. 13).

The five towers, each 250 feet high, are spaced approximately 250 feet apart. The ground system for each tower is composed of 120 copper radials each 400 feet long. The antenna ground system represents almost 130,000 feet of buried wire. WIBG owns 27 acres of land at the transmitter site, thus the extensive ground system presents no problems.

The FM antenna is side mounted on the center tower. Five sections of a BFA series FM antenna are stacked to produce enough gain to raise the 4.9 kw transmitter output to 20-kw ERP. The FM antenna is isolated from the tower by the specially designed FM isolation coil which actually isolates the 30-kw AM signal from the 20-kw FM signal on the same tower.

### Economy and Reliability

Two new transmitters capable of 10-kw output and one capable of 50-kw, plus duplicate transmission line and distribution equipment may seem unusually expensive, but the added reliability and the maintenance ease more than make up for the extra expense. Even when operating at full 50-kw power only a 45 percent increase in power bills has been noted to date. Further economy was realized during installation of the three transmitters, since no major building modifications were required.

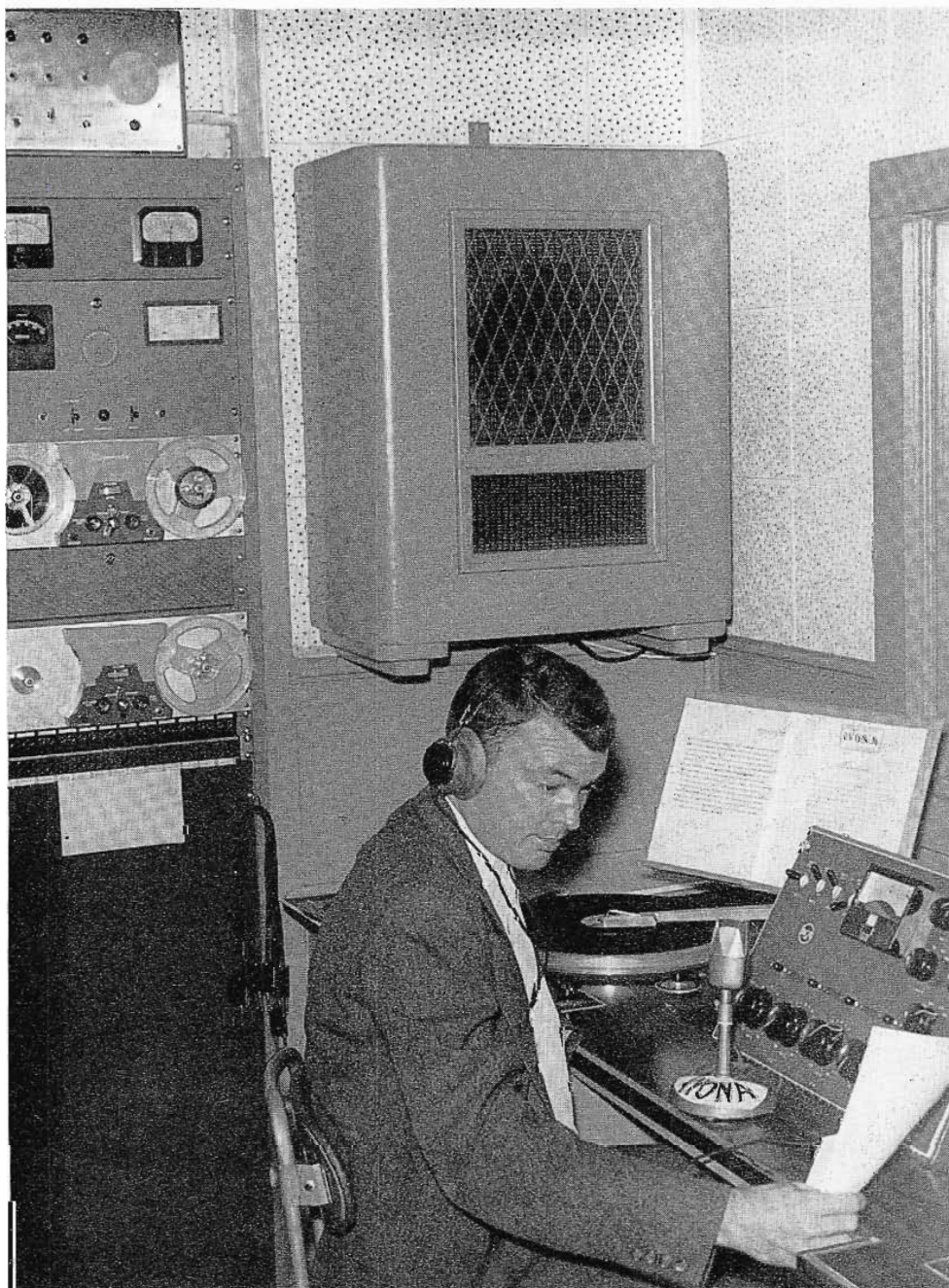

FIG. 14. The author, John H. Henninger, Chief Engineer of WIBG, has been with the station since 1936. In the past 34 years WIBG has grown from 50 to 50,000 watts with Mr. Henninger as Chief Engineer.

# WONA

## a streamlined efficient radio station

*Effective Use of Remote Control, Permits Inexpensive  
Installation of Unattended 1 KW Transmitter*



Serving the Mississippi hill and delta areas with both local and network programming, WONA in Winona is operating on 1570 KC with all new RCA equipment. The control room and studio are located in the Winona telephone building along with the stations business offices. Most unique feature of the station is the unattended transmitter which is installed in an 8 by 10 foot concrete building at the base of the stations tower.

The Southern Electronics Company owns and operates WONA and 5 KW, WAMY Amory, Mississippi. Both of these stations were completely RCA equipped by the co-owners Bob McRaney and Bob Evans. Mr. McRaney also owns WROB in West Point, Miss. WONA is run by a staff of four people headed by Bob Chisholm, who is manager-salesman.

### **Combination Studio-Control**

A single control room, designed for engineer-announcers, is used for all of WONA's operations. All control equipment has been placed at the operating position. Two Type BQ-2B Turntables have been built-in the operating desk, upon which the BC-5B consolette is mounted (see Fig. 1). The equipment cabinet at the left houses two tape recorders, jack panels, program

FIG. 1. Les Campbell, Chief Announcer for WONA at the BC-5 consolette. Built-in turntables and convenient location of speech rack make it ideal for combo operation. The BTR-11A/20A Remote Control unit is mounted just above the tape recorders in the rack.



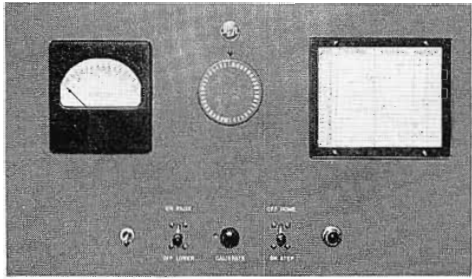

FIG. 2. This is the BTR-20 Studio Remote Control unit used at the WONA studios to control their BTA-1R transmitter on the outskirts of Winona.

amplifier, and the remote control unit for the transmitter. A Conelrad receiver has been placed on top of the rack. Figure 3 is a floor plan of the WONA studios where all programming originates.

One large studio at WONA is used for live broadcasts. Figure 4 shows Bob McRaney, general manager and co-owner of WONA, at the console of the studio organ. There is also a piano in this studio. Acoustical wall tile, and asphalt floor tile provides adequate sound isolation and good acoustical quality in the studio.

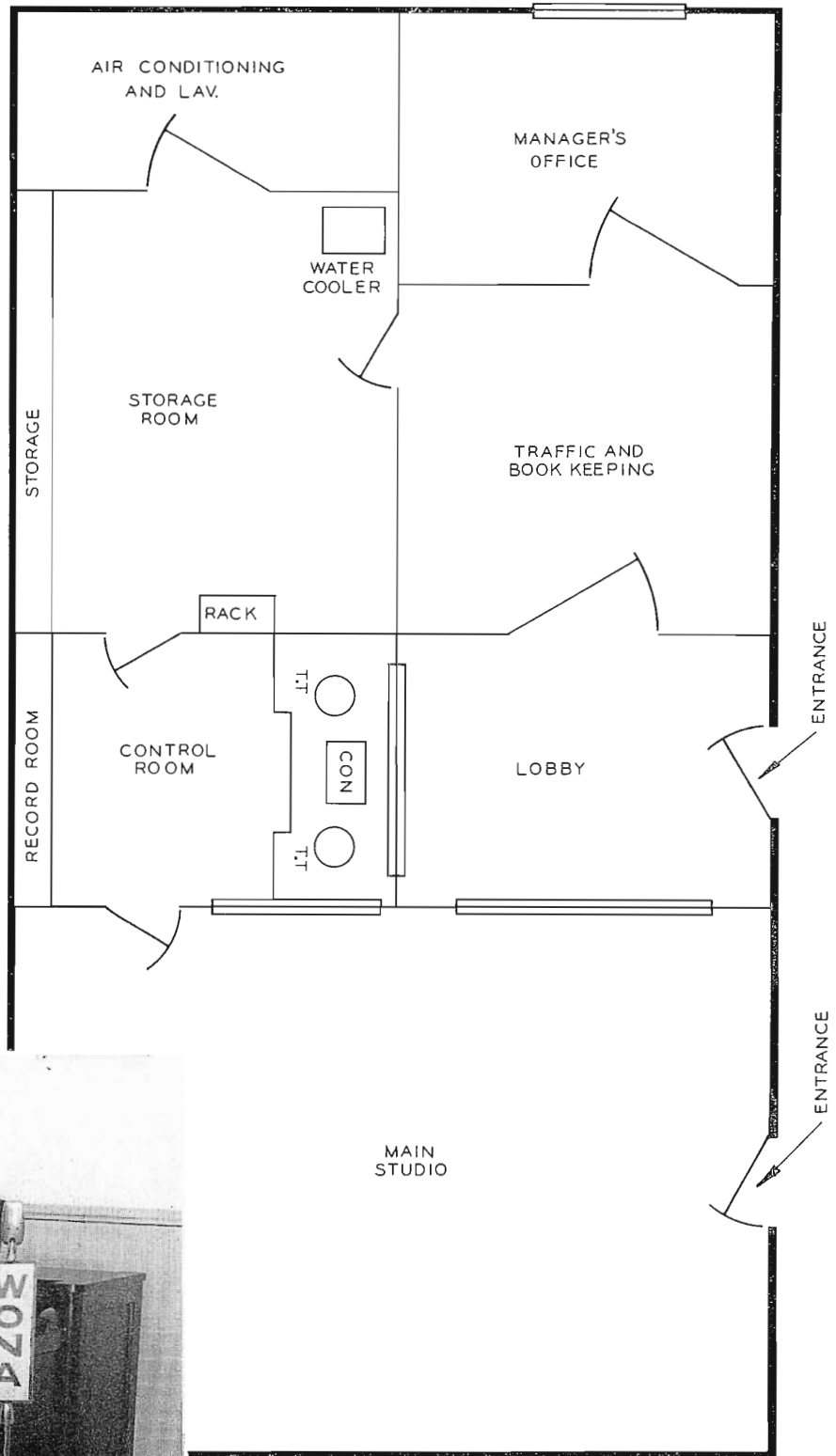

FIG. 3. WONA's studios and offices are conveniently located in downtown Winona. The main studio is large enough to handle most local programming requirements.



FIG. 4. Bob McRaney, Co-Owner and General Manager of WONA, at the console of the WONA studio organ. Mr. McRaney designed and supervised construction of all WONA facilities.



FIG. 6. The BTA-1R 1000 watt AM transmitter used by WONA. An adjoining rack contains input equipment. This type installation is ideal for stations planning to operate by remote control.

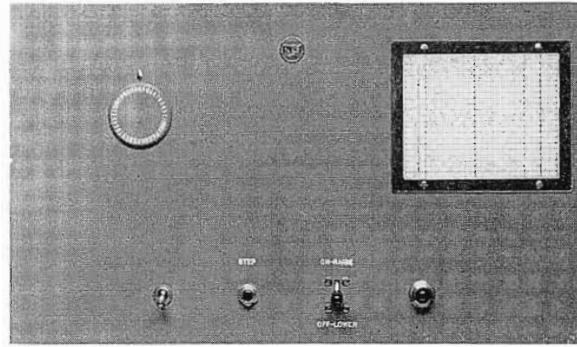

FIG. 5. This is the BTR-20A Transmitter Remote Control unit which performs all control functions on the BTA-1R Transmitter.

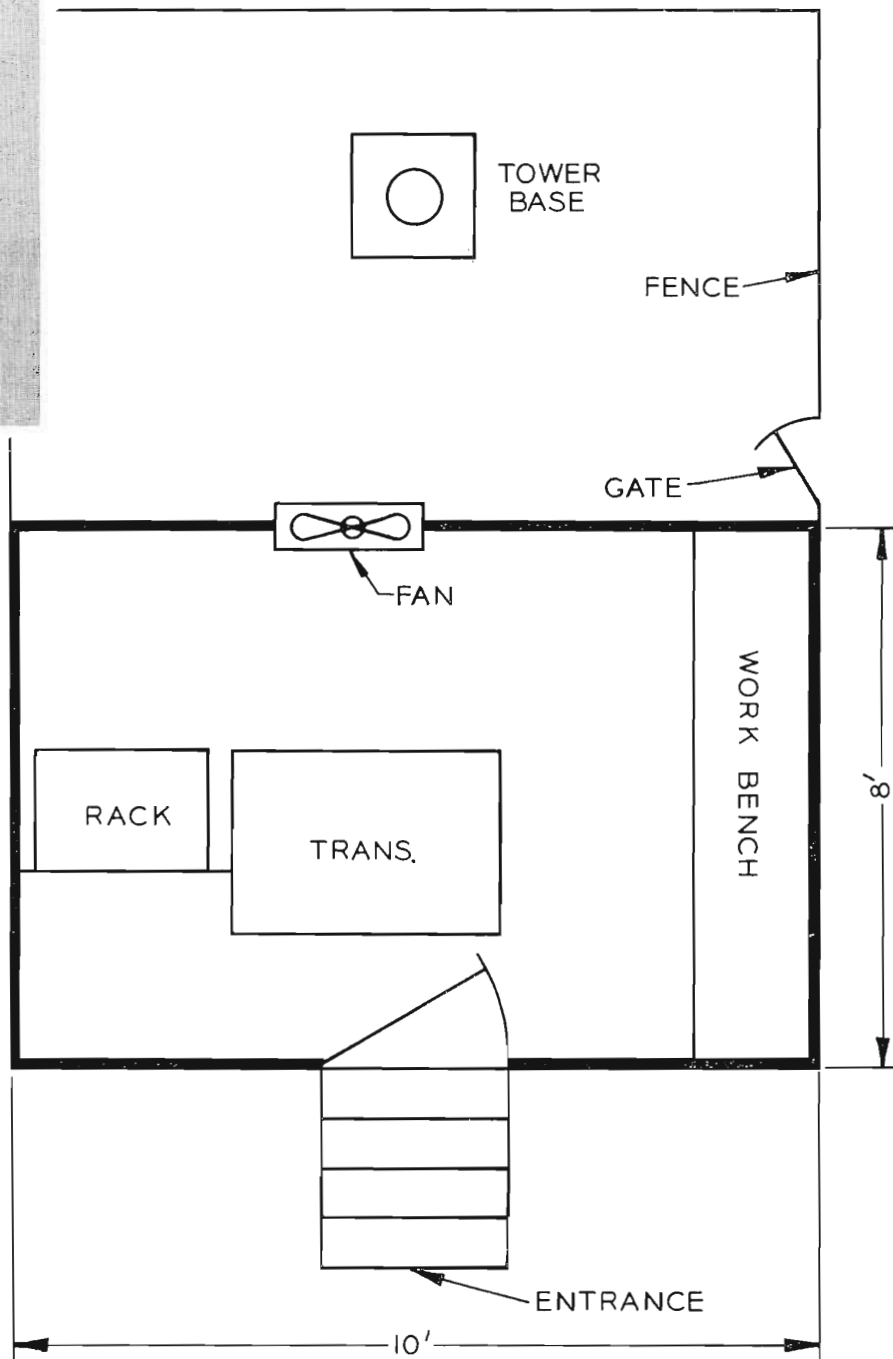

FIG. 7. This is the floor plan of the WONA transmitter building. Note generous access space to all equipment in this 8 by 10 foot building.

FIG. 8. The 206 foot Stainless steel tower dwarfs the transmitter building. The tower is mounted on a four foot concrete pier, making the total height 210 feet.

#### Remote Controlled Transmitter

An 8 by 10 foot concrete transmitter building houses the new Type BTA-1R transmitter, remote control equipment Type BTR-11A, limiter amplifier, as well as frequency and modulation monitors (see Fig. 7). This building is cooled in summer by a large exhaust fan mounted in the rear door, while in winter a thermostatically controlled electric heater is used. The flat roof of the building features a large overhang to protect against excessive sun, and the white paint also aids in reflecting sun rays (see Fig. 8).

This unusually small transmitter building does provide adequate space for the equipment and a small work bench. The warm Mississippi climate has contributed by reducing the need for more elaborate heating equipment. In the final analysis this transmitter building can almost be considered as a minimum weather shelter. The reliability of the transmitter and remote control equipment makes this type of installation more common than unique.

#### Non-Directional Antenna

Immediately behind the transmitter building is the 206-foot Stainless tower mounted on a four foot concrete pier. WONA selected this four acre tract on the city limits of Winona with a good antenna system in mind. An excellent ground system, consisting of 120 radials 200 foot long and another 120 radials each 50-foot long, was installed at the base of the tower.

#### Easy Installation

Only two months were spent in getting WONA on the air and this included erection of the tower, the transmitter building, and installation of the equipment.

Mr. McRaney, co-owner of WONA stated that, "RCA equipment was selected because of its long history of dependability, service, and ease of installation, in addition RCA equipment insures trouble free installation and operation while keeping all equipment standardized." WONA is a typical example of a minimum equipment investment 1000 watt station, yet the type of installation and equipment used will provide years of reliable service.

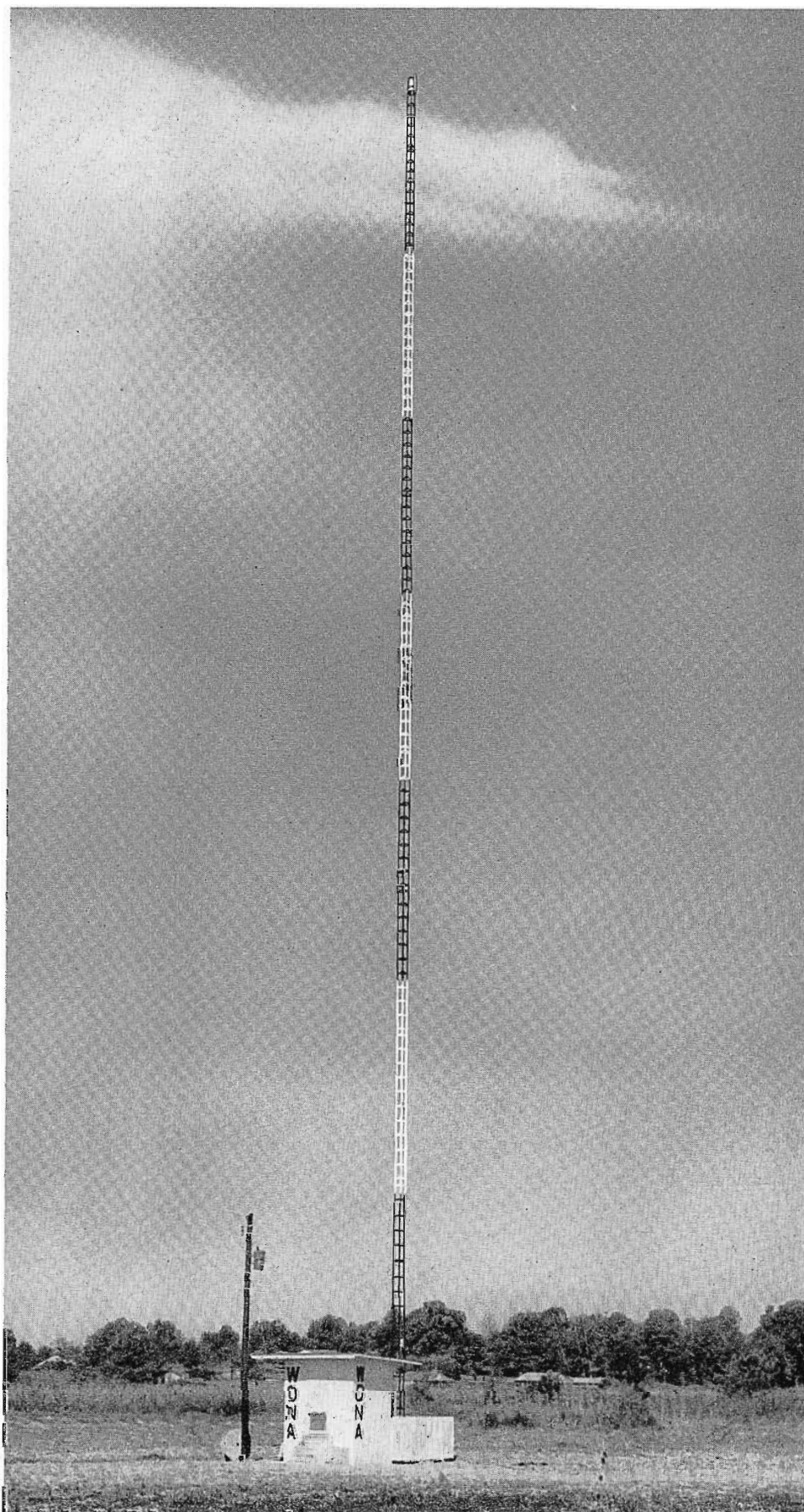

# CONSIDERATIONS IN ALIGNMENT IN

by L. W. HAESELER,  
*Broadcast and TV Marketing*

With the advent of TV tape recording, the term "quadrature" has become an important part of television parlance. There has been much discussion of quadrature alignment, the necessity for it and how it can be achieved. This article explains the considerations in obtaining quadrature alignment and why RCA has selected electronic means for this precision adjustment.

## Requirements of a Quadruplex System

In a quadruplex television tape recording system, four video heads are mounted in the headwheel at 90-degree intervals. During the recording process, the video modulated FM Signal is applied to all four heads in parallel. Each head scans the tape for a period of time slightly greater than the time required for one quarter revolution, which is  $1/960$  of a second or 1041.67 microseconds. The tape is moving at a right angle to the headwheel at 15 inches per second, producing scanning tracks which move transversely across the tape. Each scanning track contains approximately 18.4 horizontal tv lines, each of which is  $63.5 \mu\text{sec}$ . long (see Fig. 1). The period of 1041.67 microseconds, however, corresponds to 16.4 tv lines so that there is approximately a two-line overlap between any pair of successive video heads, as one leaves the tape and the other starts.

FIG. 1. Close-up of headwheel panel of the RCA TV Tape Recorder showing how video heads apply transverse tracks on tape. Tracks shown here are an artists conception of video information applied to tape. Extreme close-up below shows detail of tracks—note that each scanning track is made up of 18.4 horizontal TV lines.

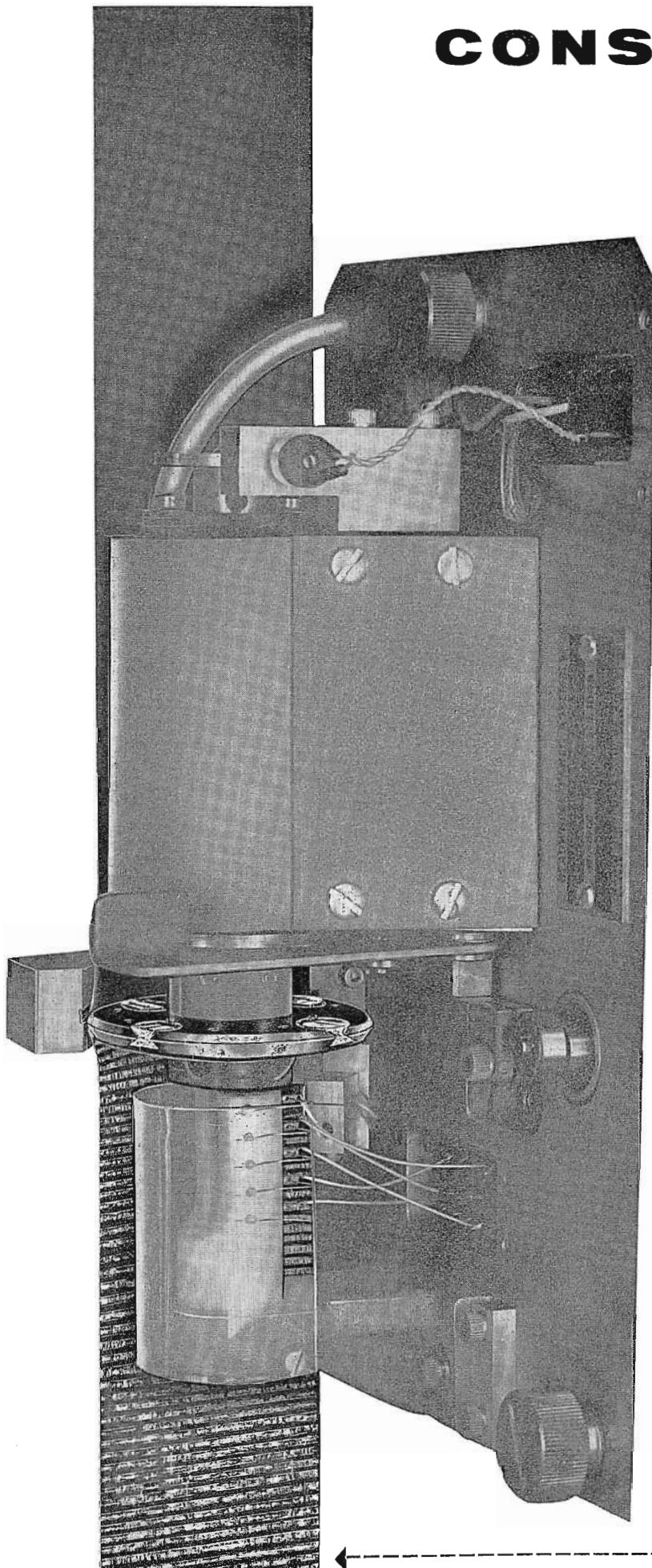

# OBTAINING QUADRATURE TV TAPE RECORDERS

The electronics which operate during the playback mode provide means for switching the output of successive heads sequentially; but since it is not desirable to switch during an active scanning line, this switching occurs during the sync interval at the end of either the 16th or 17th line in any individual video track. The number of 16 and 17 line tracks are selected so that they average 16.4 lines. (Audio and cue tracks have been ignored in this discussion, since they do not affect basic video recording process.)

## Headwheel Mechanical Tolerances

If it were possible to build a perfect headwheel in which each of the four heads were exactly 90 degrees from each other, (that is to say, a headwheel manufactured with zero tolerance on the position of the heads), no difficulty would be encountered in time displacement between individual tracks. However, a deviation in the position of the individual heads will occur in any practical manufacturing process, even using the highest precision tools available in the state of the art today. The displacement of the individual heads by *any* finite amount from exact quadrature (or the true 90-degree position) appears in the reproduced picture as a horizontal displacement of the "headbands," see Fig. 2. This effect is simply due to the video signal from a specific head arriving too early or too late with respect to the preceding head.

Cognizance was taken of this problem early in the design of the RCA Television Tape Recorder Type TRT-1. Calculations show that manufacturing tolerances, with the best facilities available, would produce this effect to an objectionable degree. This was found to be true even if mechanical vernier adjustments were made after the headwheel had been assembled.

It should, however, be pointed out here that this effect cancels itself when a tape is played back using the same headwheel which was used during the record process. The reason for this is that when an error exists in the position of any head or heads, these heads will be in exactly the same place during playback as they were during record. This results in no time displacement

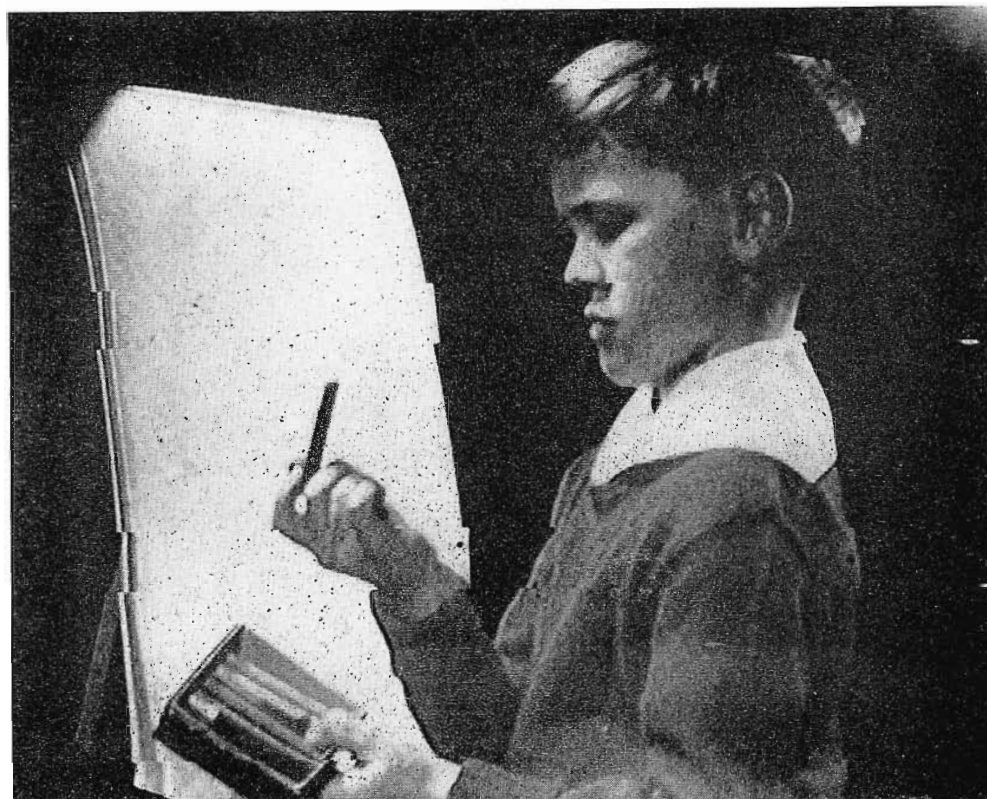

FIG. 2. The displacement of individual heads by an finite amount from exact quadrature appears in the tv picture as a horizontal displacement of "headbands." This is the effect that results—note displacement of vertical lines.

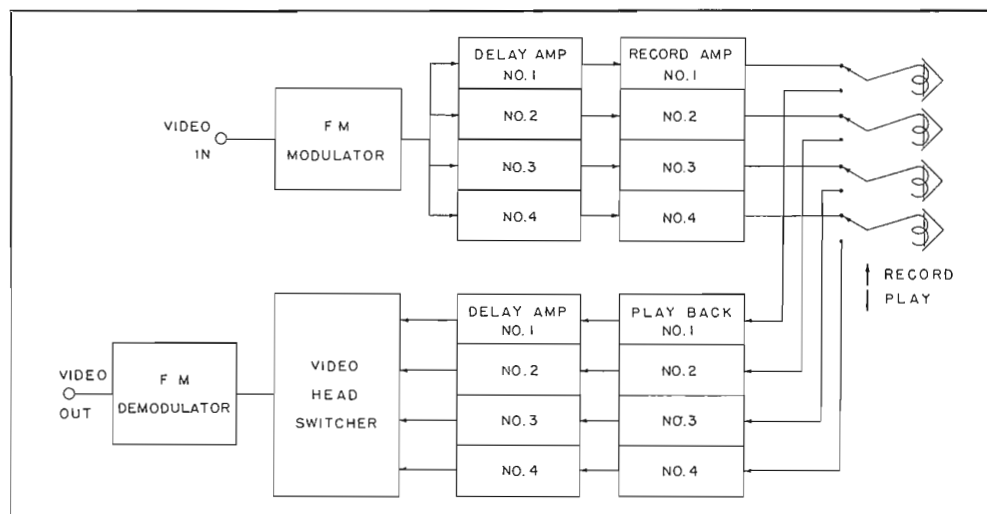

FIG. 3. Simplified block diagram showing the functions of adjustable electronic delay lines used in the RCA TV Tape equipment.

ment between successive bands. On the other hand, if playback occurs on a headwheel or other machine different from that used for recording, the relative difference in position of the head or heads will appear as time displacement.

## Electronic Adjustment of Quadrature

The design approach to effectively eliminate headband displacement in the RCA TRT-1 television tape recording system employs two sets of four precisely constructed adjustable electrical delay lines;

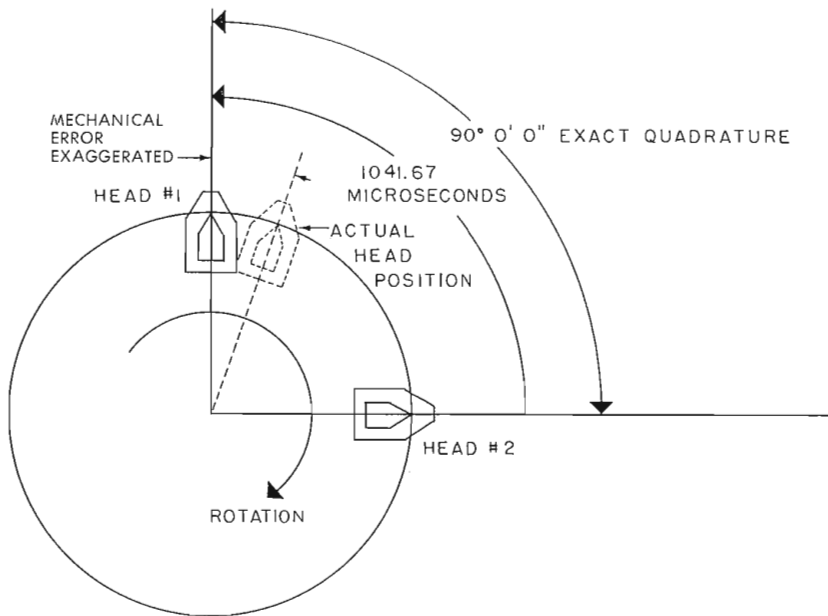

FIG. 4. Functional diagram of headwheel showing the quadrature relationship between two of the heads.

one set is used during the record operation and the other during playback. These are shown in Fig. 3. To describe the operation of these delay lines, consider the sketch, Fig. 4. Assume that head No. 1 leads or is ahead of its exact quadrature position by an error angle of, 30 seconds of arc. Then using the afore mentioned figure of 1041.67 microseconds per quarter turn, it is easy to calculate that an equivalent error in

timing of 0.09 microseconds will occur with this amount of physical displacement. This calculation is as follows:

1.  $90 \text{ deg} = 5400 \text{ min} = 324000 \text{ sec}$
2.  $\frac{1041.67}{324000} = .00322 \text{ } \mu\text{sec per sec of arc}$
3.  $.003 \times 30 = 0.09 \text{ } \mu\text{sec error}$

This amount of displacement is shown in Fig. 5.

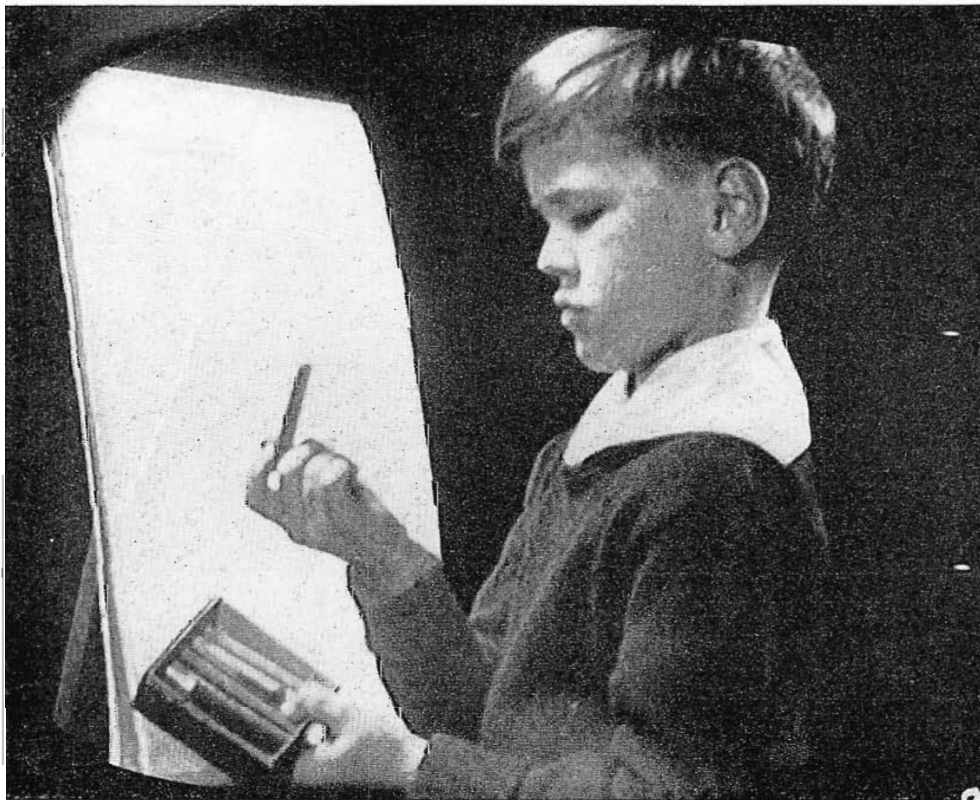

FIG. 5. Monitor display of a television picture recorded with a head-to-head displacement of 0.09 microseconds.

### Simple Checkout for Recording

A test tape is supplied with each TRT-1 Tape Equipment. It is made under controlled conditions so that negligible quadrature error exists. Playing back such test tape on a headwheel with quadrature error will quickly demonstrate the amount of error in each head channel. Then by rotating the appropriate tap switch on the playback lines until the horizontal displacement disappears, a direct reading of the error existing in that specific head channel is indicated. The difference between the initial and final settings for no observable error represents the amount of delay required to offset the physical displacement from its correct position.

The delay line switches provide steps of 0.03 microseconds each, and after a new headwheel panel is installed and with the playback lines in nominal mid-range, the test tape is played and the playback lines adjusted for zero horizontal displacement. To assure making correct tapes, the record lines may now be set for the proper amounts of delay by using an equal but *opposite* amount of correction that was used in the corresponding playback delay line. For example, if head No. 1 required an additional advance of three steps from nominal mid-position for correct playback, then line No. 1 on the record delay chassis is set for minus three steps to offset this effect. The process may be continued for heads 2, 3, and 4.

*Once set, the record delay lines need not be changed until a new headwheel panel is installed in the machine.* The record lines are therefore mounted near the bottom of the No. 1 rack of the operating center.

### Adjustments Convenient to Playback

The playback lines, on the other hand, may be used at any time if a tape which exhibits quadrature errors is played back. The appropriate tap switches are adjusted until horizontal displacement is corrected (see Fig. 6). This is quickly accomplished by depressing a shortcircuiting button provided on the playback amplifier to identify any given band in a picture with its corresponding head.

All correction is accomplished during operation of the machine; and, in actuality, correction for recorded error can be made in a matter of a very few seconds after playback starts.

If a mechanical, manufacturing tolerance of  $\pm 15$  seconds of arc ( $\pm 0.045 \text{ } \mu\text{sec}$ ) is

FIG. 6. Playback electronic quadrature adjustments are made on a conveniently located chassis at the TV Tape operations center. Four tap switches are available here—one for each head on the headwheel.

used in making headwheel assemblies, the maximum timing error between any successive pair of heads can be  $+30$  seconds ( $0.09 \mu\text{sec}$ ). If a tape is recorded under these conditions, but played back on a headwheel whose corresponding heads are at the other end of the tolerance limit,  $-30$  seconds, then the total effective error will be 60 seconds, which is  $\pm 0.09$  or a total of  $0.18 \mu\text{sec}$ . This is shown in Fig. 7.

By employing  $0.03 \mu\text{sec}$  taps (10 secs of arc) on the delay lines, it is possible to set for  $\pm 0.015 \mu\text{sec}$  in each channel. Many subjective tests show that this amount of error is indistinguishable from zero error. On a 21-inch monitor, it represents a displacement of .006 inches which is appreciably smaller than the nominal monitor scanning spot diameter of .030 inches.

The effect of quadrature error is sometimes confused with other types of distortion which may occur in a television tape recorder, notably the effect of too little or too great pole tip penetration, as well as non-concentricity of the headwheel and vacuum shoe. Improper pole tip penetration creates the familiar saw-toothed or "jogged" effect and is automatically compensated for in the TRT-1 through the head shoe servo. Concentricity of the headwheel and vacuum shoe is a mechanical adjustment, and an incorrect setting produces an effect known as "scalloping." This adjustment, however, once set, will ordinarily remain correct for the life of the headwheel panel.

#### Precision Control of Effective Quadrature

Electronic quadrature adjustment as provided by the RCA TV Tape Recorder is very helpful in playing back tapes made on recorders without the advantage of this precision circuitry. Should band displacement appear on the outgoing monitor, adjustments can be made by visual observation while the machine is actually in operation. In most cases correction can be accomplished in seconds, permanently correcting disparities for the entire program run. Introduction of this technique has enabled precision control of quadrature relationship, greatly advancing the state of the TV Tape art.

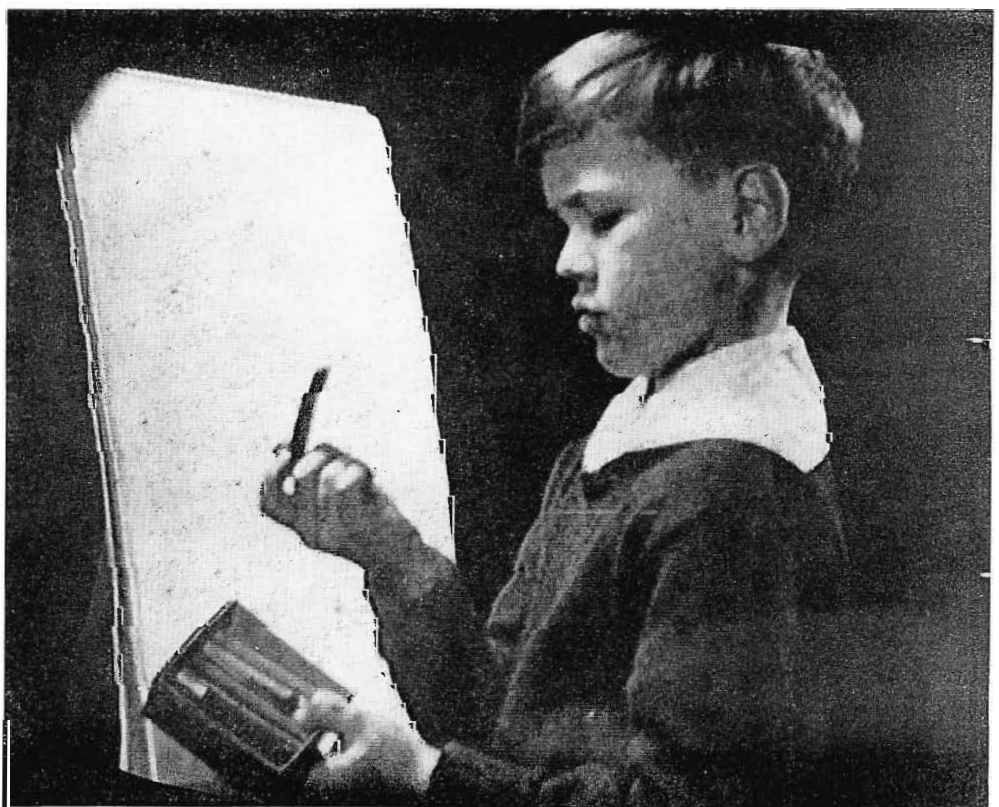
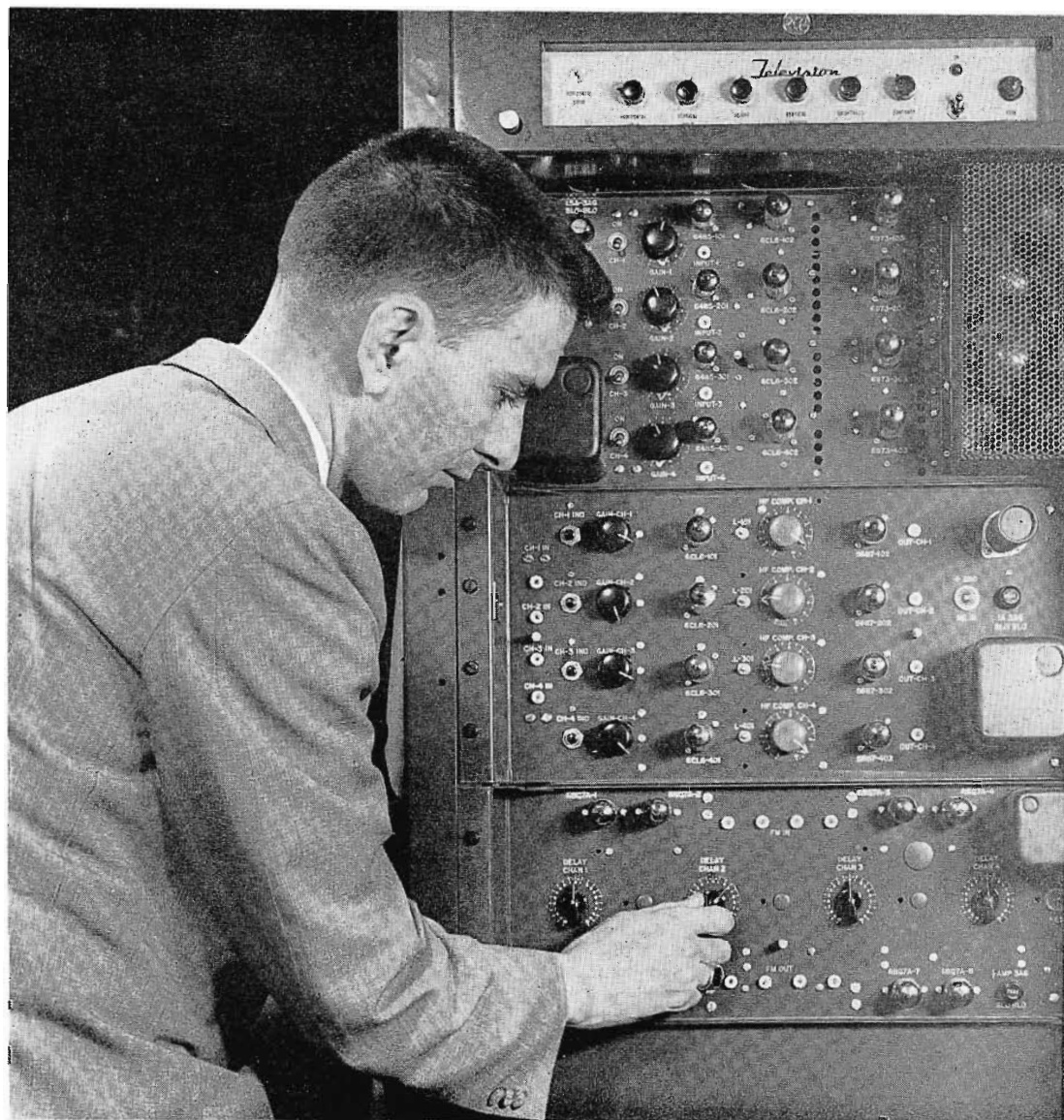

FIG. 7. Monitor display of a television picture recorded with a head-to-head displacement of 0.18 microseconds.

# TV TAPE BOLSTERS WISN-TV

Sports fans in baseball-conscious Milwaukee can look forward to a full Winter of the national pastime, and professional and college football, taped on RCA advanced TV Tape recorders. Two TV Tape ma-

chines have been installed at Milwaukee station WISN-TV and have been put to work immediately. The recorders play a key role in a planned series of special Saturday night sports programs this Fall and Winter.

## ABC Pro Game of the Week

Program plans include taping the Saturday night ABC professional football game of the week (on No. 1 machine) starting at 9 P.M. (Milwaukee time). An hour and 15 minutes later, No. 2 machine will be used to broadcast the earlier action as part of the WISN-TV sports program, with No. 1 machine continuing to record the network transmission. The same procedure will be followed during the balance of the National Football League-ABC exhibition schedule.

## Marquette University Home Schedule

During the Marquette University football season, opening against the University of Pittsburgh, WISN-TV will make tape recordings of all Saturday afternoon home games and play back the tapes at 1 P. M. Sundays.

"This is the result of an agreement reached with university officials," Station Manager Bill Goodnow reports, "and should work to the advantage of both the university and our television audience. Those who attend a Marquette game should welcome the opportunity to relive

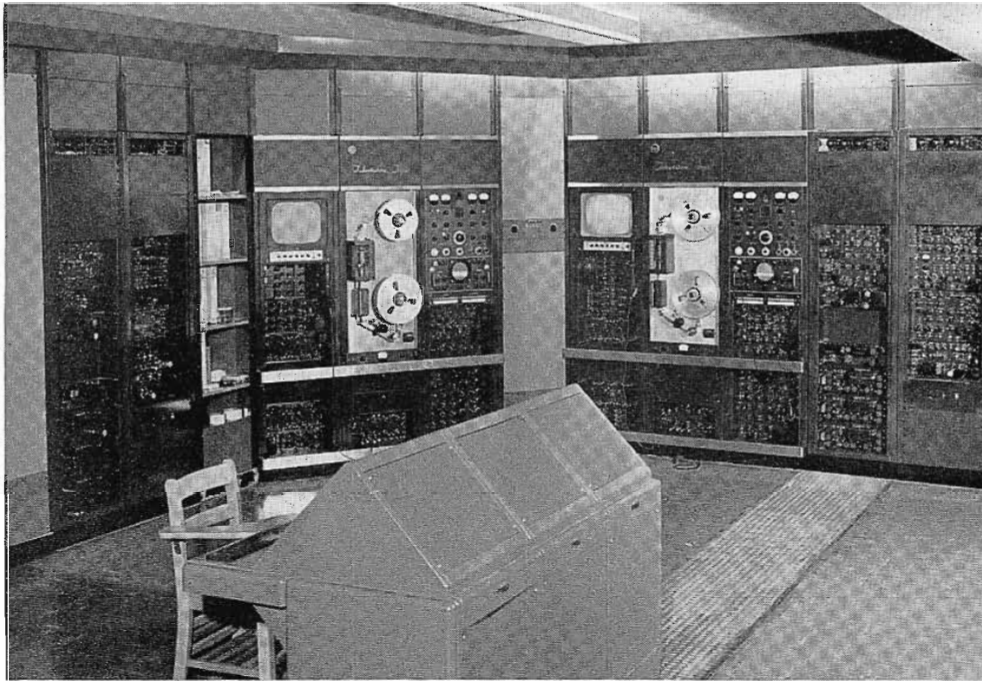
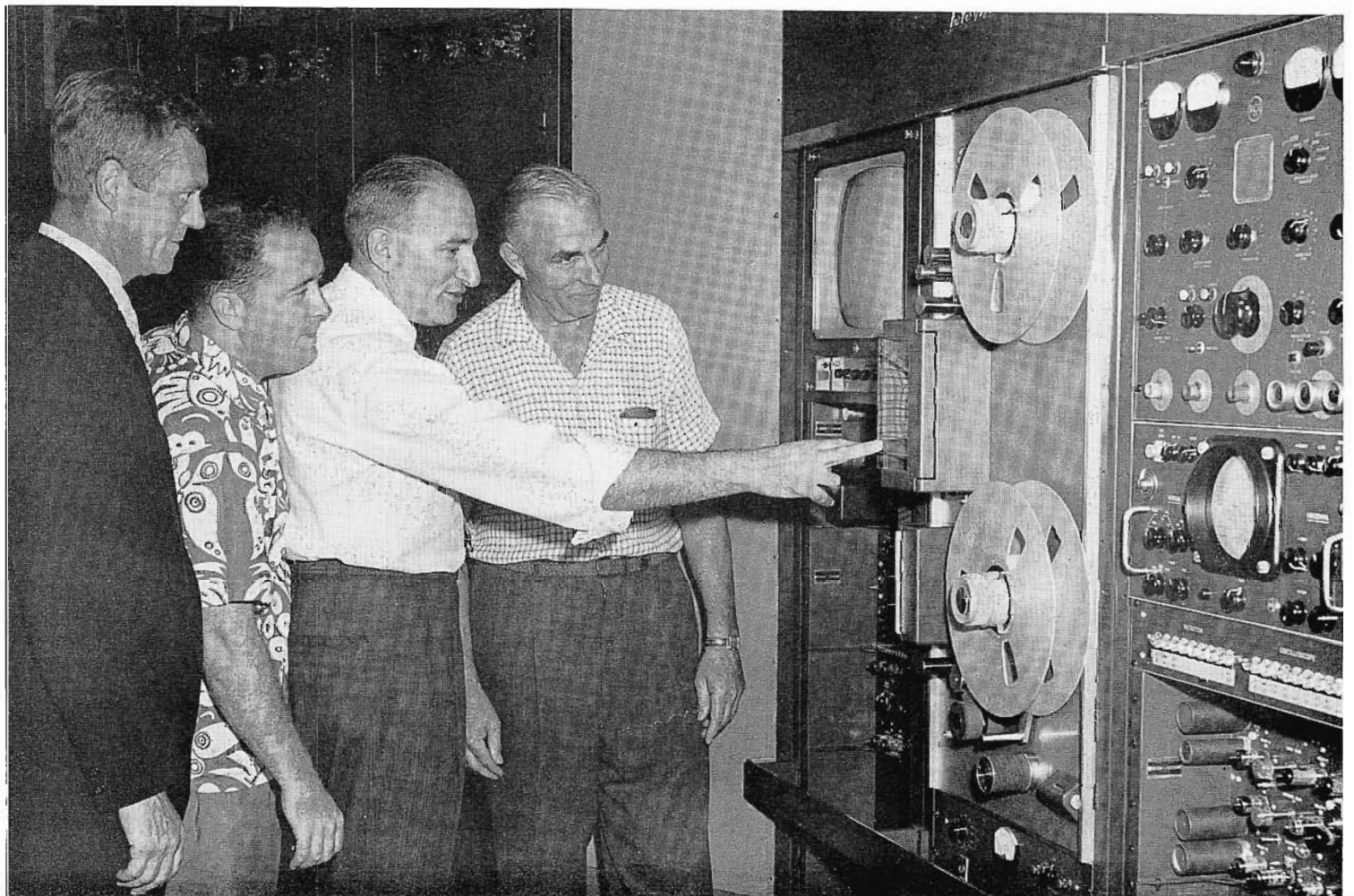

FIG. 1. Two RCA TV Tape Recorders installed at WISN-TV control room. Both machines will be used to tape the ABC pro football game of the week—delaying program time to fit the station's Saturday night schedule.

FIG. 2. Lionel Wittenberg, WISN-TV's Chief Video Engineer demonstrates the new TV Tape equipment. Looking on, left to right, are William C. Goodnow, General Manager; Tony Flynn, Sports Director and "Liz" Blackburn, Marquette University head football coach.





# SPORTS SCHEDULE

the action, while those who couldn't make it will see a TV picture of 'live' quality."

## Winter League Baseball

WISN-TV is completing arrangements to obtain TV tapes of winter league baseball from Cuba. These will be incorporated in the 10:15 P.M. Saturday sports show. "Practically nothing is as close to the heart of a Milwaukee sports fan as baseball," Mr. Goodnow said. "There has been widespread demand for TV presentation of winter league games."

FIG. 3. Shipment of the WISN-TV equipment from Camden to Milwaukee was made by padded van. This kind of handling made it possible for station personnel to make the installation and begin operation with a minimum of time and effort.



## FIRST TV TAPE SEMINAR HELD

Television station representatives from six states attended the first in a series of seminars on the operation of the advanced RCA tv tape recorder. Held at the Camden, New Jersey, plant the 3-day seminar featured instruction in the circuitry and functions of the RCA recorder. Each of the attending station personnel given an opportunity to setup and operate the equipment themselves. Similar seminars are planned on a semi-monthly schedule.

Attending the first seminar were: G. L. McClanathan, KPHO, Phoenix, Arizona; J. H. Butts, KBTB, Denver; W. S. Sadler

and L. A. Larson, KSTP, Minneapolis; Howard Daubenmeyer, WTRF, Wheeling, West Virginia; Lionel Wittenberg and Martin Johnson, WISN-TV, Milwaukee, and John Wilner, Parke Plowman, David Nolan and P. R. Spangler, WBAL-TV, Baltimore.

The sessions were conducted by C. H. Colledge, General Manager, RCA Broadcast Equipment Division; E. C. Tracy, Manager, Broadcast Equipment Marketing; J. W. Wentworth and A. H. Lind, Broadcast Engineering, and E. T. Griffith, Manager, Broadcast Customer Relations.

FIG. 1. Each of the station engineers in attendance were given an opportunity to set up and operate the tv tape equipment themselves. Here J. H. Butts of KBTB, Denver, checks over one of the equipment chassis.

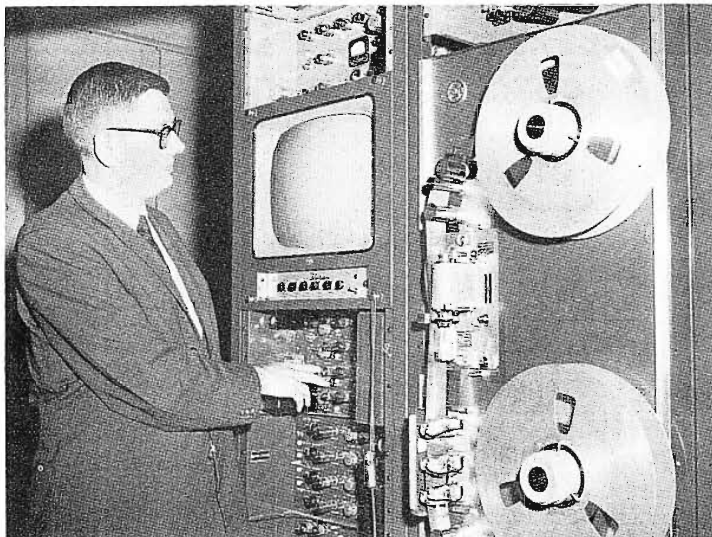
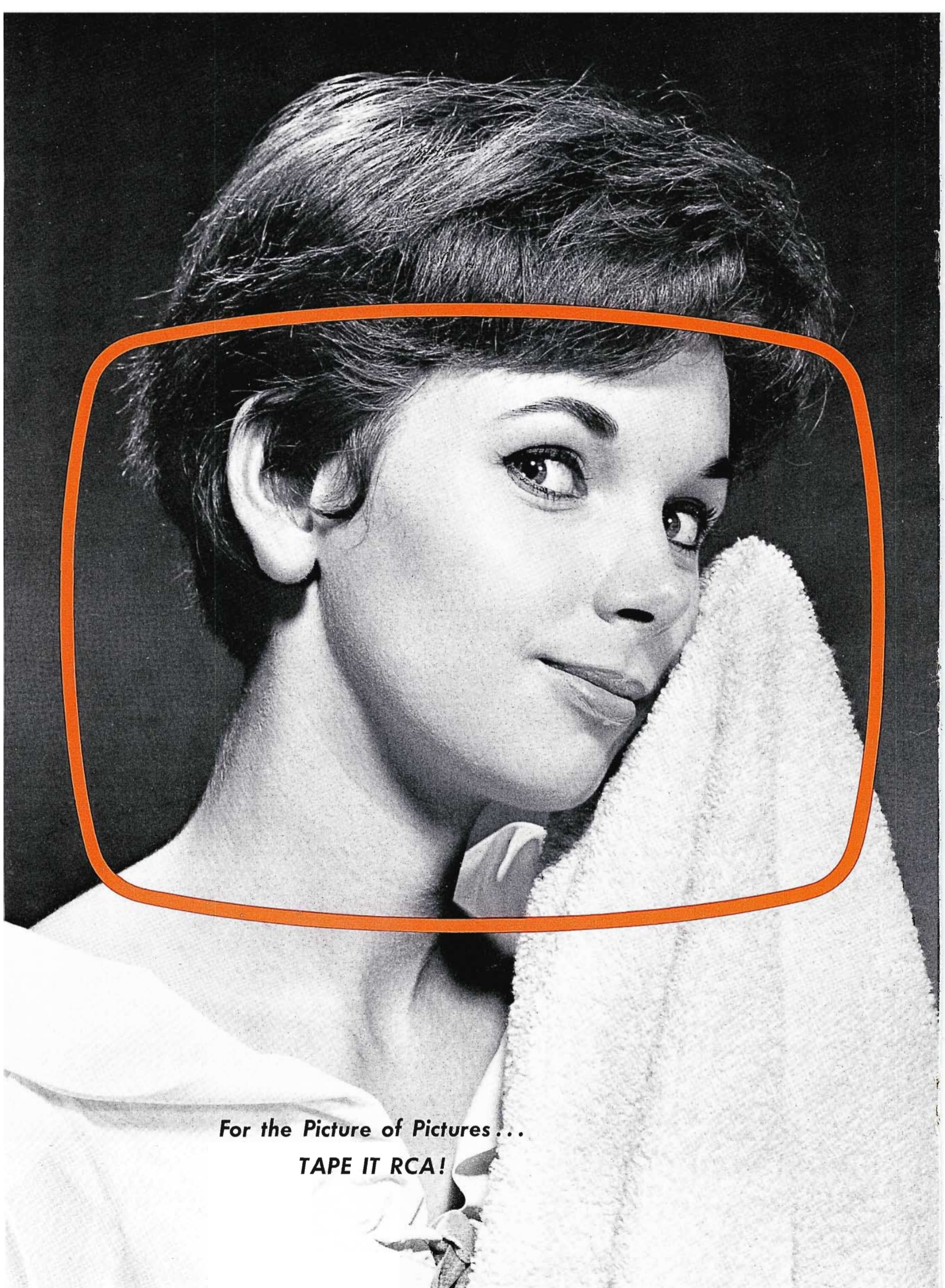

FIG. 2. Group picture of television representatives who attended the tv tape seminar. Eleven engineers representing six stations were on hand to study operation and maintenance of RCA advanced tv tape recorder.





*For the Picture of Pictures...*  
**TAPE IT RCA!**

**GIVE YOUR TAPES**

**A TOUCH OF**

**RCA GENIUS!**

The same genius and craftsmanship that pioneered in the development of television . . . from cameras to transmitters . . . has now conceived an advanced TV Tape Recorder. This is equipment that's compatible in every respect—you would hardly expect anything less from the leader in television. With the most precise adjustments possible on any tape recorder, recording and playback of tapes is inherently superior. Even tapes recorded on improperly aligned machines can be "optimized" in a few seconds while the tape is on the air. Newest arrival on the TV Tape scene, the RCA recorder offers many improvements over older designs . . . ingenious features which make it easy to get and keep pictures of superb quality . . . features such as *electronic quadrature adjustment, sync regeneration, four-channel playback equalization, built-in test equipment.* Don't settle for less than the best! See your RCA Representative. Or write to RCA, Dept. TR-3, Building 15-1, Camden, N. J. In Canada: RCA VICTOR Company Limited, Montreal.

ANOTHER WAY RCA SERVES INDUSTRY THROUGH ELECTRONICS



Tmk(s) ®

**RADIO CORPORATION of AMERICA**

BROADCAST AND TELEVISION EQUIPMENT

CAMDEN, N. J.

# WBAL-TV INSTALLS TV TAPE

**Station Engineers Install RCA TV Tape in 1 Hour and 45 Minutes — from Loading Dock to Playback of First Recorded Program Segment**

In a timed test of newly developed factory testing, packing and shipping techniques, WBAL-TV engineers have installed an advanced RCA TV Tape Recorder in the record time of 1 hour and 45 minutes. Each step of the installation was carefully timed: placement at the loading dock, setting equipment in place in the film room, interconnection of auxiliary racks with the operations center, power checkout, recording and playback. This timing check proved out the effectiveness of techniques employed in RCA's factory check-out of TV Tape Equipment. Key steps in the operation are illustrated on these pages—a clock has been included in each of the photos to document the time schedule for the completed installation.

## Speedy, Straight-Forward Installation

Pre-planning by station engineers using information supplied by RCA also accounted for the ease with which the installation was accomplished. The WBAL-TV film room had been readied, cable ductwork installed, and interconnecting power and video cables pulled into place. At 10:26 a.m. the advanced TV Tape Recorder was on the station's loading platform ready to be transported by elevator to the third-floor film room. About a half hour later the equipment had been removed from its special packing and set in place in the film room ready to be interconnected.

Equipment design speeded power and video interconnections. All connections at the operations center racks are attached at that end and are brought out in a special wiring harness designed to readily interconnect the RCA TV Tape Recording System. The only interconnections to be made by station engineers are those from this harness to terminal blocks conveniently

located at the rear of the two power and auxiliary racks. Shortly after noon all interconnections had been made, checked and rechecked, and the equipment was ready for testing with power on. Power was applied rack by rack. Everything proved to be in order.

As a final test, a two minute segment of WBAL-TV programming was recorded at 12:08 and played back at 12:11 p.m. Performance was excellent, the same sharp, high-resolution, low-noise pictures that were obtained in factory checkout were reproduced at the station—without adjustment.

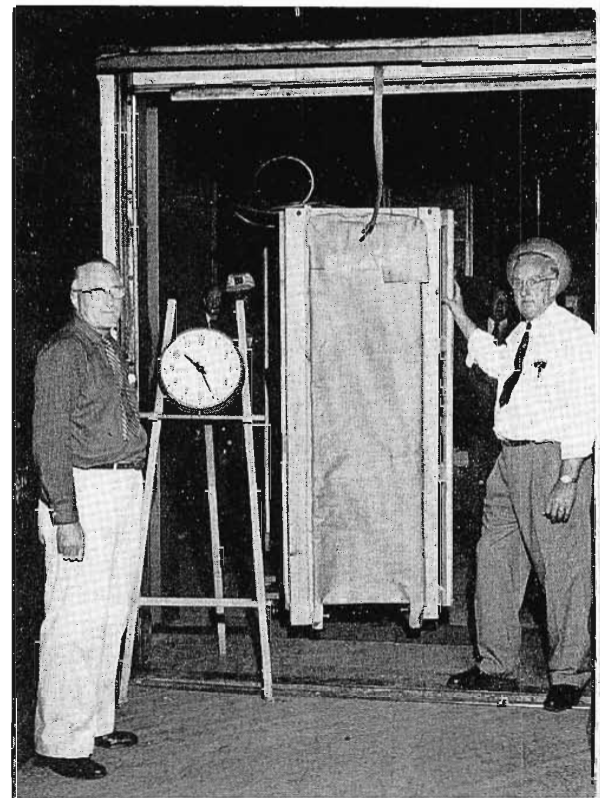
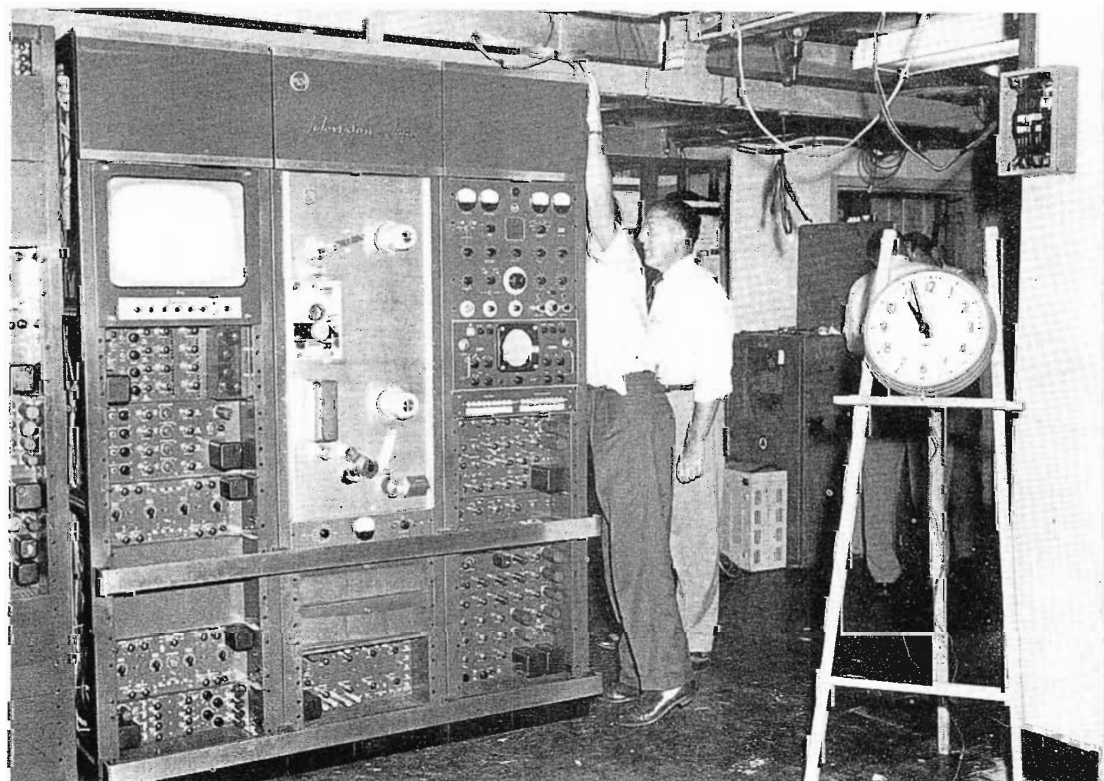

FIG. 1. Start of the time test for TV Tape installation at WBAL-TV. Operations center racks in special packaging are ready to be moved on to the elevator to transport them to the station's third floor film room.

FIG. 2. In about a half hour all tape equipment has been set in place in the station film room. Here operations center racks are being lined up below the ductwork which carries video and power cables.



### On-Air at Once

Station management and engineers, present for the final test, were in complete agreement that the equipment performance had met their high-quality standards for on-air use. Copy for a special station-break announcement to accompany the station's first use of advanced TV Tape was prepared, and the 12:45 station break was recorded and played back on tape. In addition, a five minute portion of the station's one o'clock studio originated program, "What Do You Think," was recorded and then played back later in the same show. Response from viewers was enthusiastic. In letters to the station they applauded the live quality and reported it was impossible for them to distinguish the live from the taped material.

### Station Plans

WBAL-TV Station Manager, Brent Gunts, reports that the advanced TV Tape Recorder, first of two which were purchased by the station, will provide viewers with a far more flexible live-quality programming schedule. By the same token, advertisers will benefit from WBAL-TV's ability to record commercials in advance and present them at the most opportune and effective time with the full impact of live programming.

In addition to playing back daytime highlights of the Nikita Krushchev U.S. tour, the RCA TV Tape Recorder will be immediately employed for the more efficient programming of locally-originated material. For example, WBAL-TV now broadcasts a live bowling program on Tuesdays and Saturdays and plans will include taping the Saturday bowling show shortly before making the live pickup on Tuesday. The tape would be held over for broadcast on Saturday. This allows the station to make most efficient use of time and personnel for remotes.

Also, a program entitled "Fair Exchange," telecast Saturday afternoons with the cooperation of the University of Maryland, will be taped in advance for the greater convenience of both station and university personnel. Similar production convenience is also planned in taping a Saturday afternoon garden show and a Sunday afternoon children's program.

### Live Quality Programs

With the installation of a second advanced TV Tape Recorder, already completed, station plans will be further implemented. The live quality of tape will bring new impact to WBAL-TV programs to the benefit of viewers and advertisers alike.

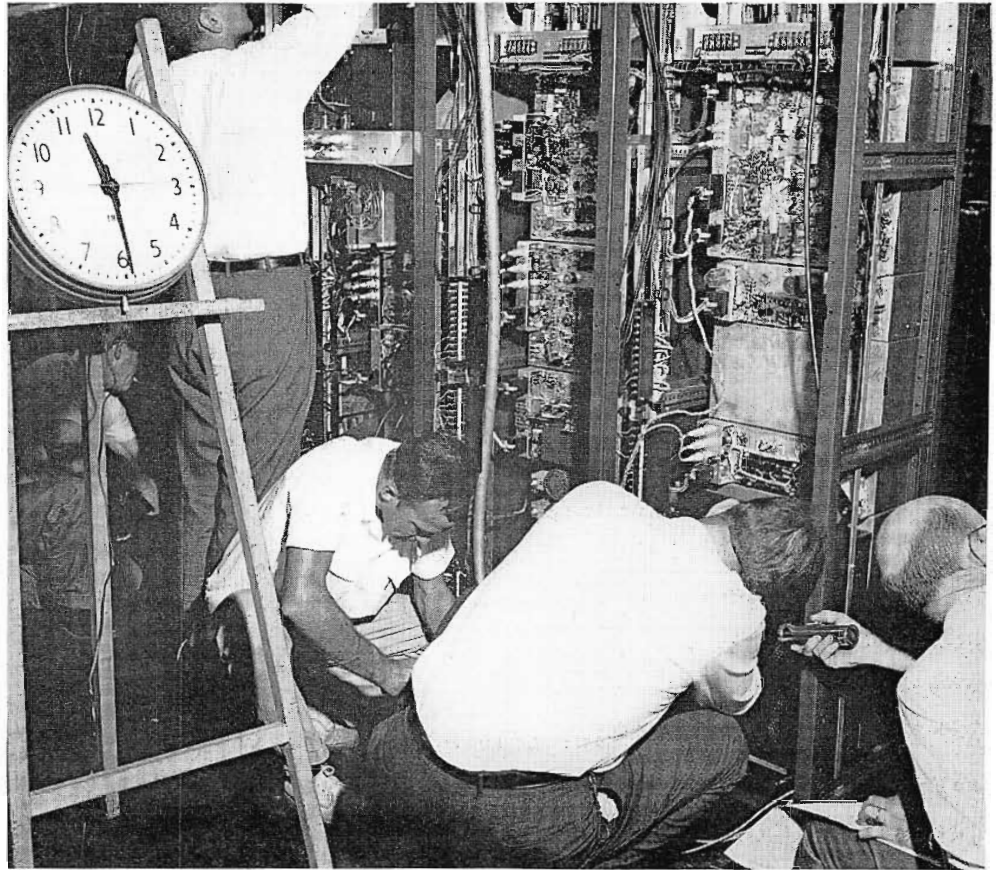

FIG. 3. Engineers make interconnections from specially designed wiring harness to terminal blocks located in the rear of power and auxiliary equipment racks. These are the only interconnections required in the advanced TV Tape equipment.

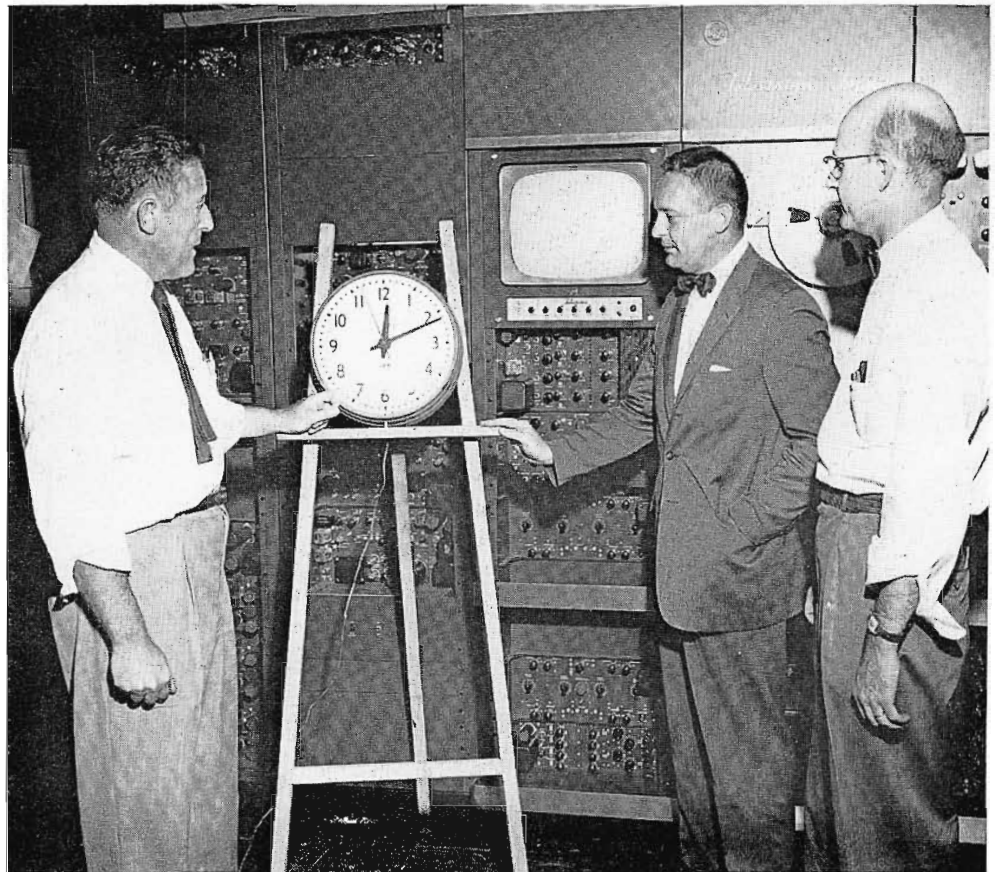

FIG. 4. Playback of the first recorded segment was made at 12:11 p.m. John Wilner, WBAL-TV Vice President of Engineering, Brent Gunts, Station Manager and Roy Marian, RCA Engineer check the clock signifying the end of the time test.

# LOWRY AIR FORCE BASE TELEVISION TO IMPROVE

*Use of ETV System Requires Fewer Instructors and Less Equipment, but Produces Better Graduates*

Lowry's Department of Bomber Training set Air Force history early this year when its first class ever to receive technical training entirely by closed television was graduated. Initiated by Major Gen. E. P. Musset, Center Commander, and under the personal guidance of Col. J. W. Hughes, Center Operations Officer, the Bomb Navigation Systems Mechanics course is being taught solely by means of television. "Although educational television is not new in itself," Col. Hughes points out, "Lowry's application of it is a history-making pro-

ject, which is being closely watched by the Air Force. Other civilian and military projects have, in the past, televised small portions of courses, but Lowry is the first to televise all of a complex technical course."

Test results to date indicate that the television trained student learns and/or retains about 8 percent more of the course materials than the conventionally trained student. It should be pointed out that in obtaining these results and comparisons the

best possible instructors available were used in the conventional classes, a situation which does not normally exist in all conventionally trained classes due to the shortage of the highly qualified technical instructor.

Experience indicates that televised instruction at Lowry will save two MA-Systems (at approximately \$180,000 each). These systems, currently set aside for ground training will be freed for other use.

FIG. 1. The motto of Lowry Air Force Base is: "Our Mission is Training." Accordingly, all the latest methods of teaching, including Educational TV, are being employed. As a result, the Air Force is being supplied with a continuous flow of highly skilled technicians.



# EMPLOYS CLOSED CIRCUIT TECHNICAL TRAINING

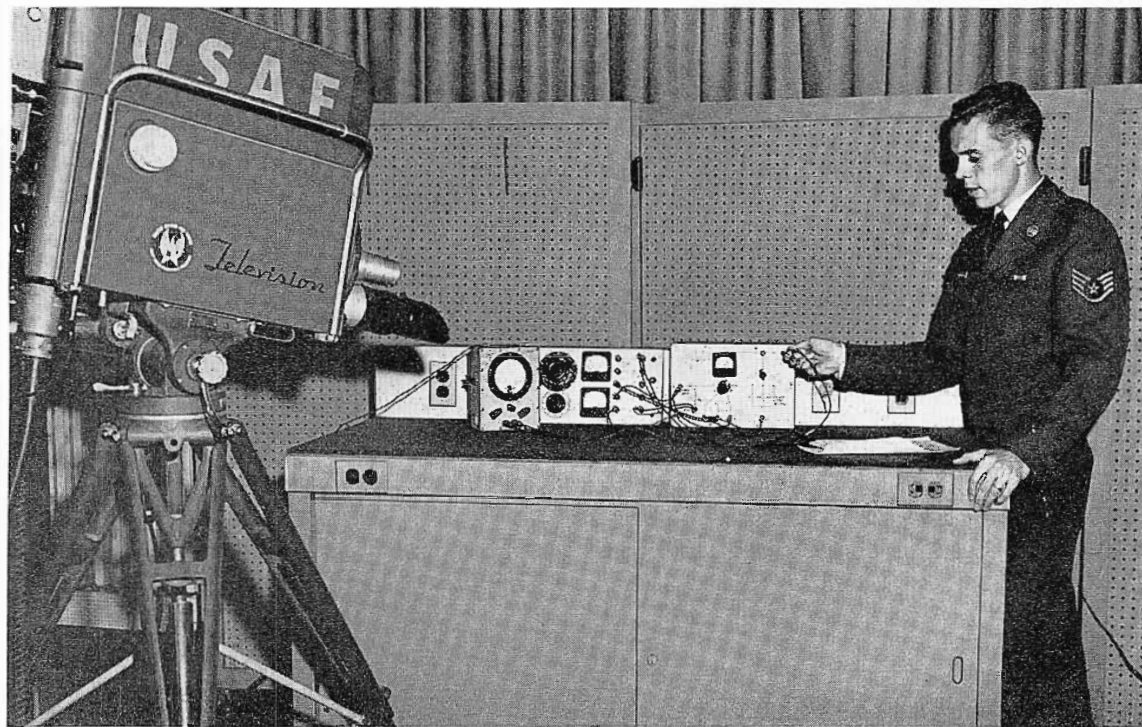

FIG. 2. Closed Circuit Television is used to teach fundamentals of electronics for one half of each teaching day—a period of three hours.

## Three-Hour Periods

The Class received its entire 24 academic weeks of training by means of television. Programs originate from two studios and are sent by coaxial cable to the classrooms. The television teaching day is divided into two three-hour periods. During the first session, students view the equipment they are studying and see it demonstrated and discussed by their television instructor.

During the following three-hour laboratory period, the students work with the actual equipment, performing adjustment, alignment and trouble-shooting procedures which they have seen on television. The lab period is under the guidance of classroom proctors and the television instructor's supervision.

## ETV is Ideal Medium

It has been found that fundamentals can be easily taught without constantly moving students from class to lab. This makes the training equipment available to more students. Thus, TV helps Lowry to handle more students with less equipment as well as raise the quality of instruction.

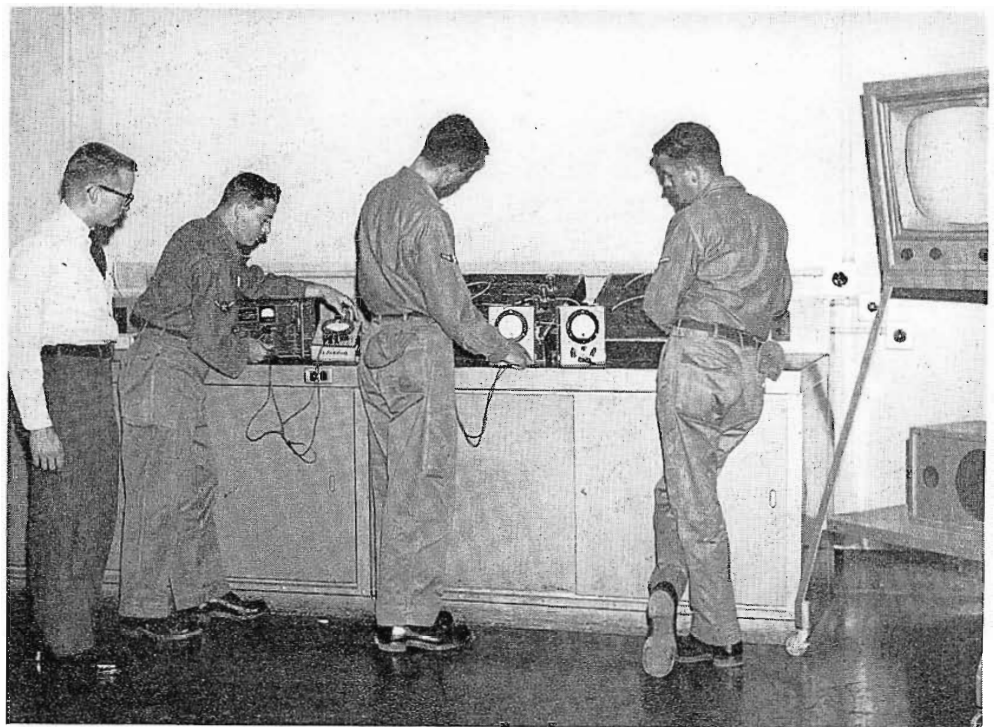

FIG. 3. The students spend the last half of each class day in the lab, working with actual equipment.

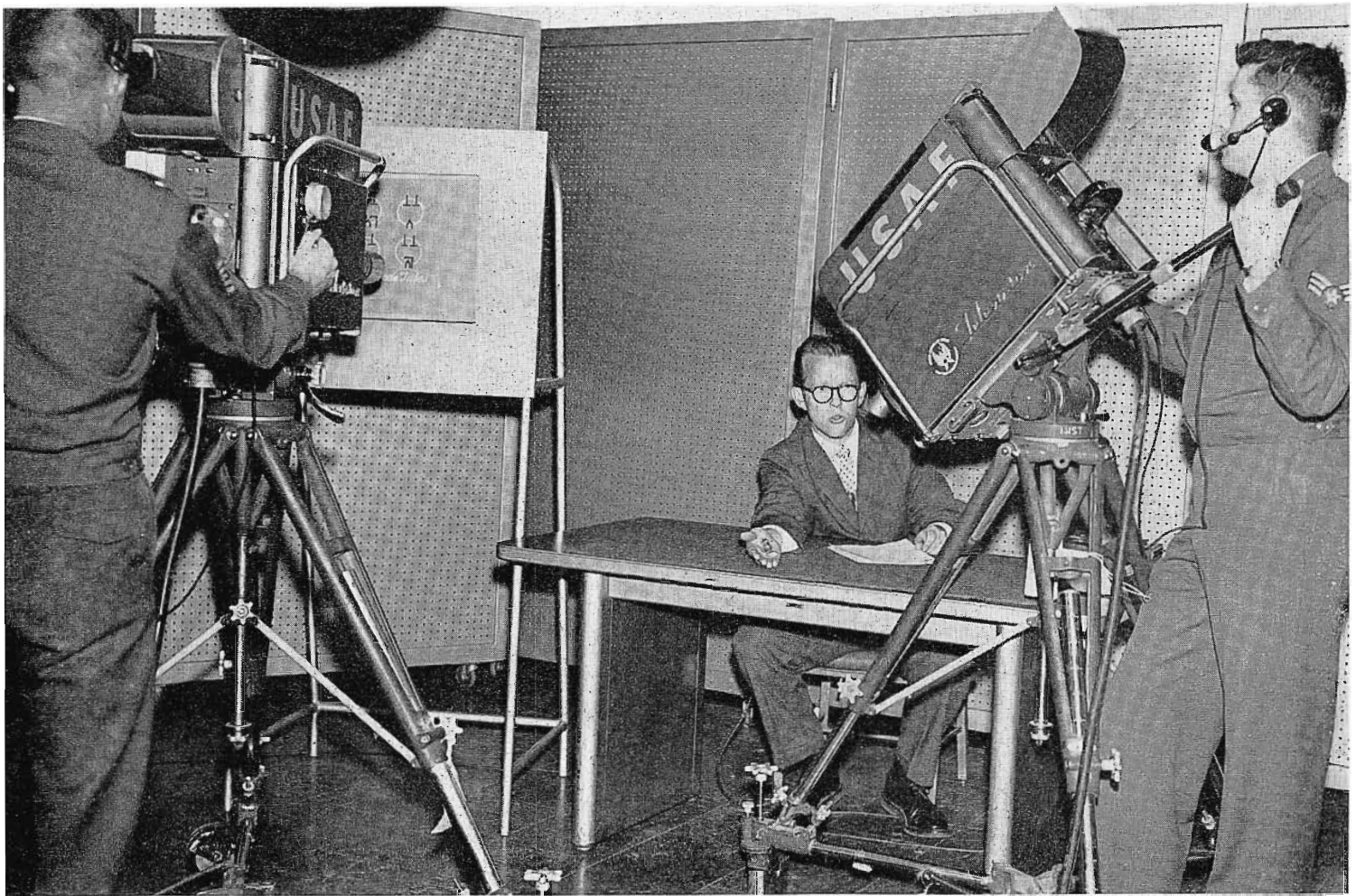

FIG. 4. A two-channel TV system is used for maximum effectiveness in teaching.

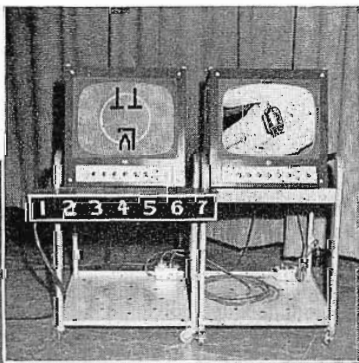

FIG. 5. In the classroom, students can ask questions and receive replies by means of a 2-way audio circuit. Inset shows monitors in studio—lighted number indicates question from classroom. Note microphone in student's hand.



### Dual-Channel TV System

The video system is a two-channel operation—that is, each classroom has two monitors. At the director's discretion, through switching devices, the students are able to observe a separate picture on each monitor. For example, a trainer can be shown on one, the corresponding electrical schematic on the other, and the student can make comparisons between the two. Again, front view of a component can be shown on one monitor, and a side view can be shown on the other monitor, to give improved orientation and comprehension.

### Questions and Answers

Students can ask questions of the TV instructor and receive his answers. The system is arranged to operate through the proctor in each class, who passes the microphone to the students and punches the question button. The instructor sees a lighted number under his studio monitor indicating class where question originates and, when he is ready, asks for the question. Discussion then goes back and forth, until student is fully informed. All the classes hear both sides of the discussion. In this way the instructor maintains personal contact during each lesson period.



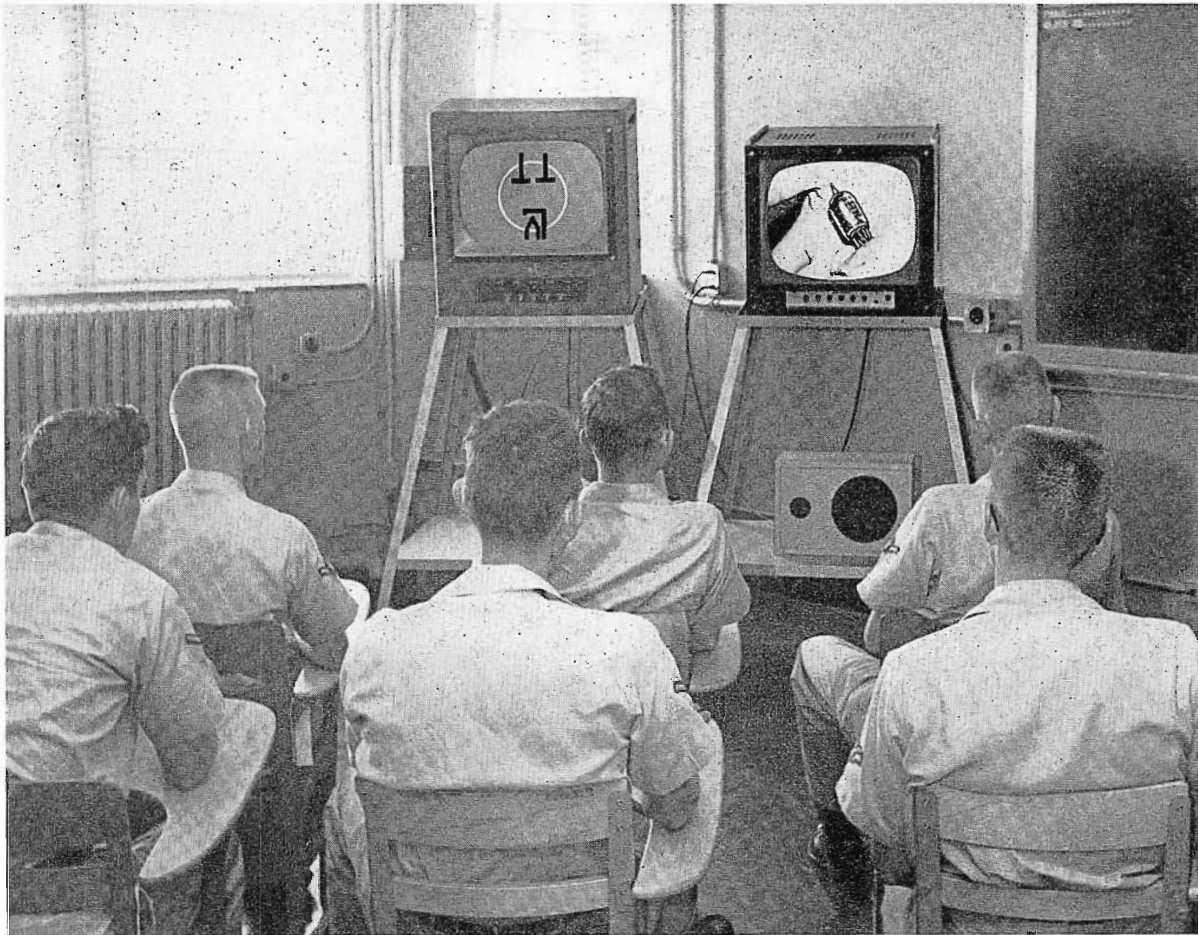

FIG. 6. Using the two-channel TV system, the students see two pictures at the same time. This saves students a great deal of time, eliminates a search for reference material.

FIG. 7. The Center Commander, Major Gen. E. P. Musset (right) and his Operations Officer, Col. J. W. Hughes (left) keep in close touch with the type of teaching used to train electronics technicians.



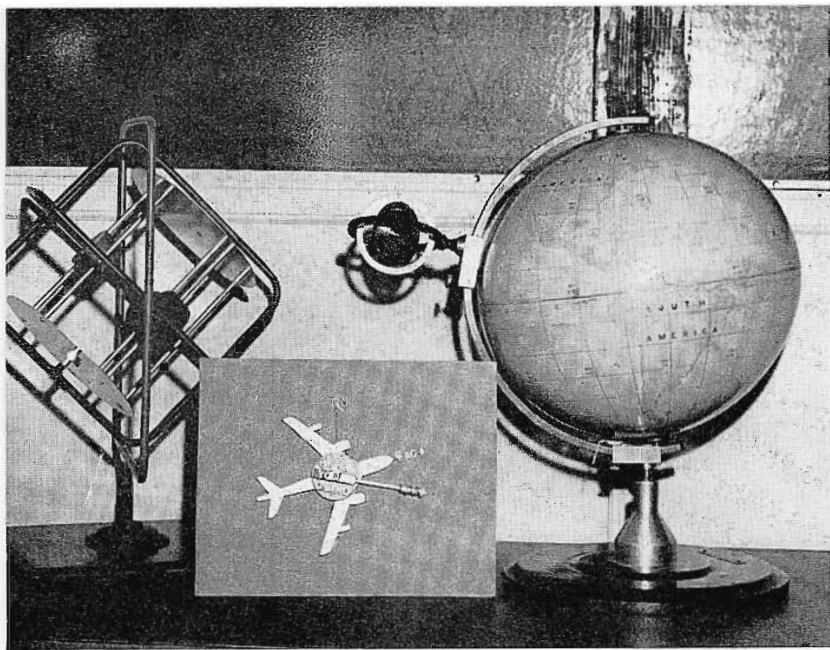

FIG. 8. Here are some of the demonstration devices especially designed for teaching via TV.

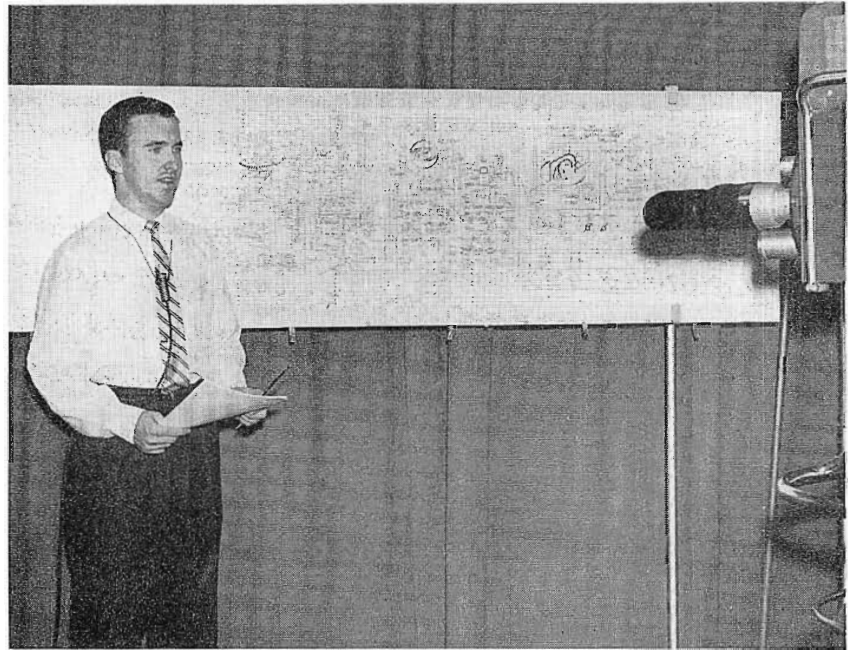

FIG. 9. This extra-length chart holder enables the instructor to trace complicated circuits with maximum effectiveness.

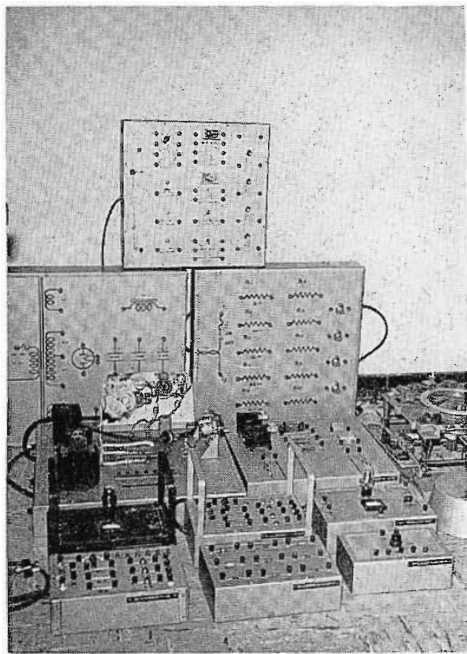

FIG. 10. Especially constructed trainers help speed the learning process.

#### Instructor-Director Team

It has been found that the ideal combination for teaching effectively via TV is a team approach. Cameramen, floormen, instructor and director rehearse together as a complete team. The director sits at the control console giving directions to all on the team, as well as switching pictures. The cameramen move cameras about as directed—from instructors to equipment—from diagram to demonstration, etc. The floorman gets charts, diagrams, and equipment in place before the camera. He flips the charts and moves equipment into position.

#### Control Classes

The television project draws its students from the normal course entry. Students being taught by television are matched, insofar as possible, with other students being taught by conventional methods. Matching is based on such factors as stanine scores, intelligence, educational background and other personal factors that may be available in student records. Two classes are formed, as nearly alike in backgrounds and ability as possible—one class section taught by closed-circuit television, the other by conventional methods. Comparisons are made

FIG. 11. Flip charts are used to illustrate points. The floor man reads the charts at the precise moment.

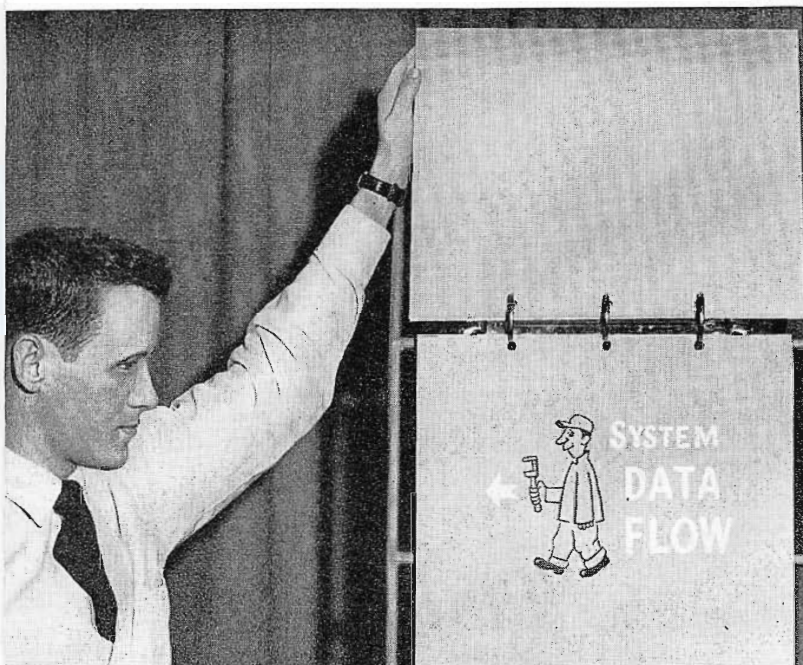
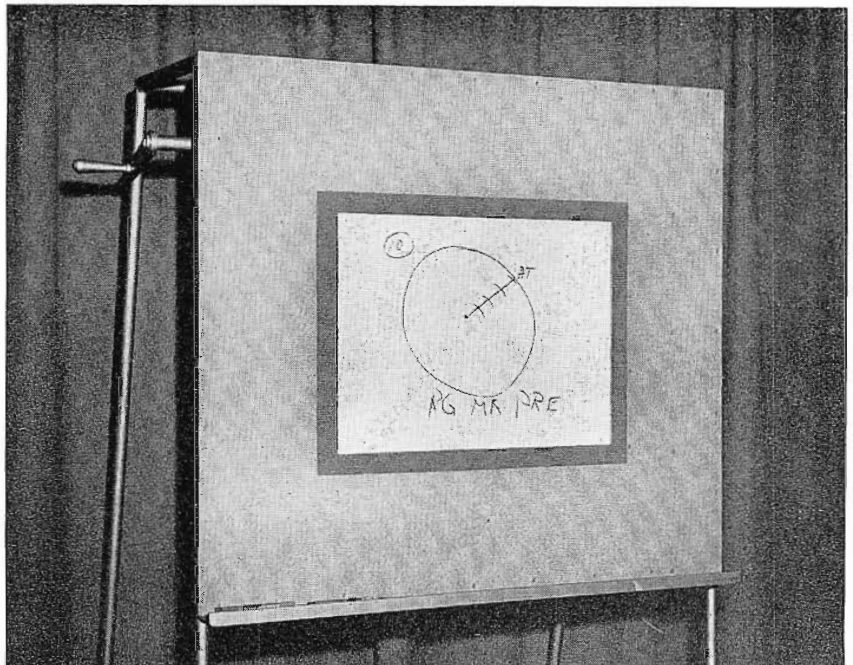

FIG. 12. A so-called "Roller Board" is used in lieu of a blackboard. No erasing is required. A turn of the crank brings a clean surface. A reverse turn brings back a previous sketch.



between the two classes in terms of knowledge and skills attained during their course of instruction.

### Expansion Capability

Additional students are being added at the rate of 45 per week compared to a former rate of 5 per week. This large increase would be a staggering load under conventional teaching, which would require 120 additional instructors. But with TV this increase can be easily handled. It is only necessary to install additional monitors, no increase in instruction being required.

### Graphics Aid TV Teaching

Numerous devices created by Lowry administration officials have contributed considerably to the effectual use of TV as a teaching medium. Charts, trainers, and demonstration units have been designed and constructed. Holders for flip cards, roller boards, and crawls have been built by Lowry personnel. These reveal the enthusiasm that instructors and administration personnel have for the TV medium.

### Improving the Course Via ETV

Under General Musset, Lowry AFB has had a continuing program for improving its training course. As a result of keeping track of graduate students, the course material has been more and more perfected and instructors better prepared for the text. TV is now assisting in this program of improvement by making more widespread use of the best instructors and enabling these instructors to present the course material in the most effective manner.

### Major Benefits From ETV

Col. Jack Hughes, monitor of the TV Training Project, has this to say about TV, "We are reaping three major benefits in our teaching program:

"First, we are using our qualified instructors to better advantage. They can be used to teach many more students than in the conventional way. Hence, we have more effective utilization of instructors.

"Second, insofar as course material is concerned, we are able to exercise more definite control. Course content is strictly scrutinized and polished. The required rehearsals enable us to preview our course before presentation and to perfect it.

"Third, with respect to the student, we believe that we make it easier for him to drink in the significant parts of the course. Every student sees and hears exactly what he should. There are no distractions, no inability to see. The instructor achieves the closest to a one-to-one ratio that is humanly possible."

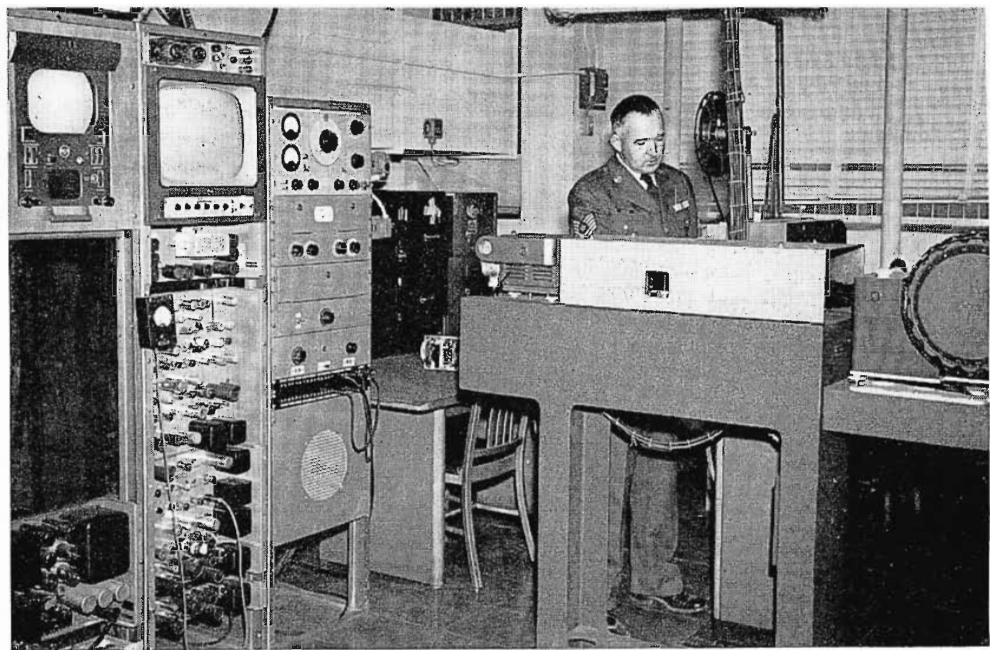

FIG. 13. Television film room. From here slides and movies can be integrated into the instructor's teaching program.

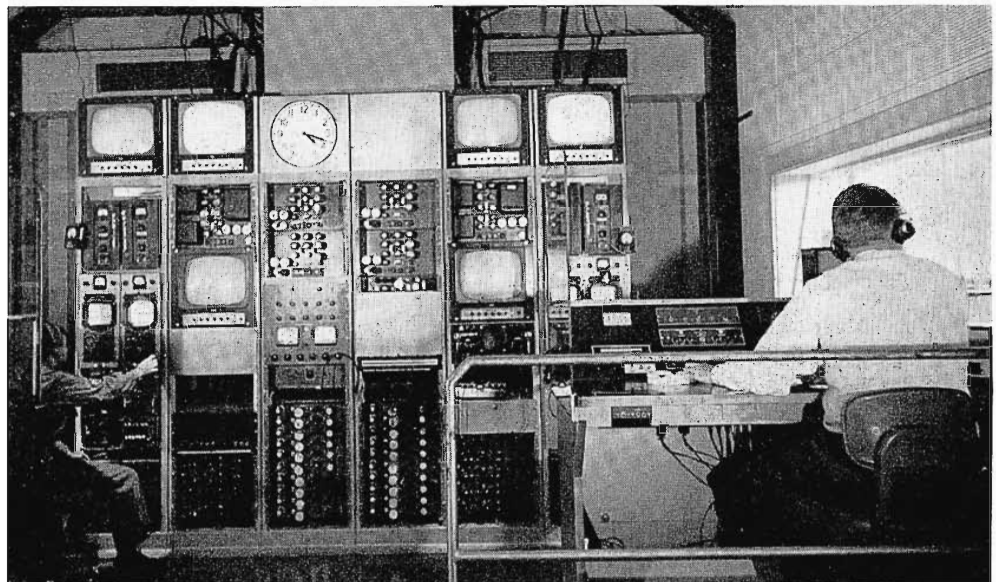

FIG. 14. Studio control room showing director (right) at TV control console. (A similar control position is at left for studio No. 2.)

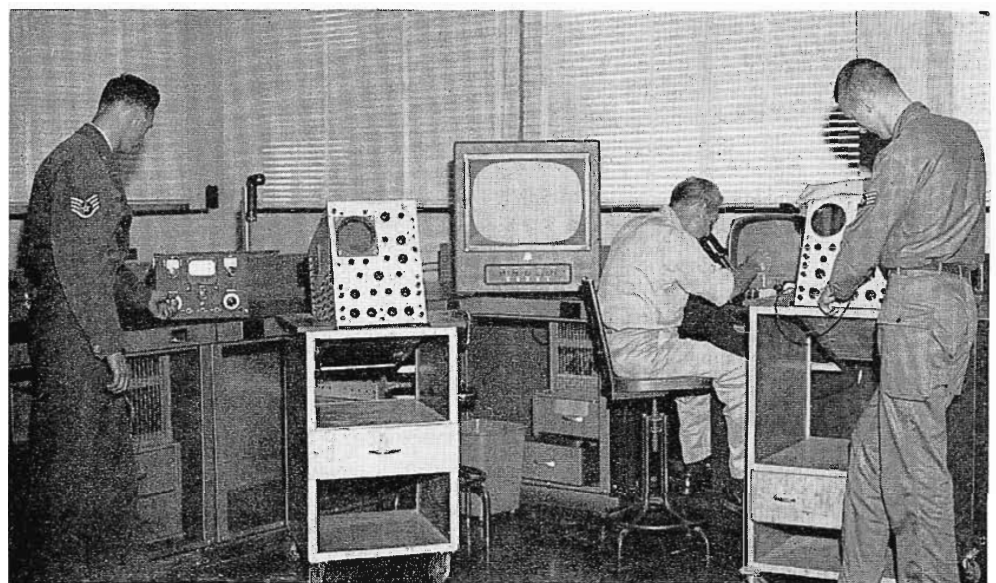

FIG. 15. Television maintenance is carried on by Lowry Airmen who are part of the TV staff.

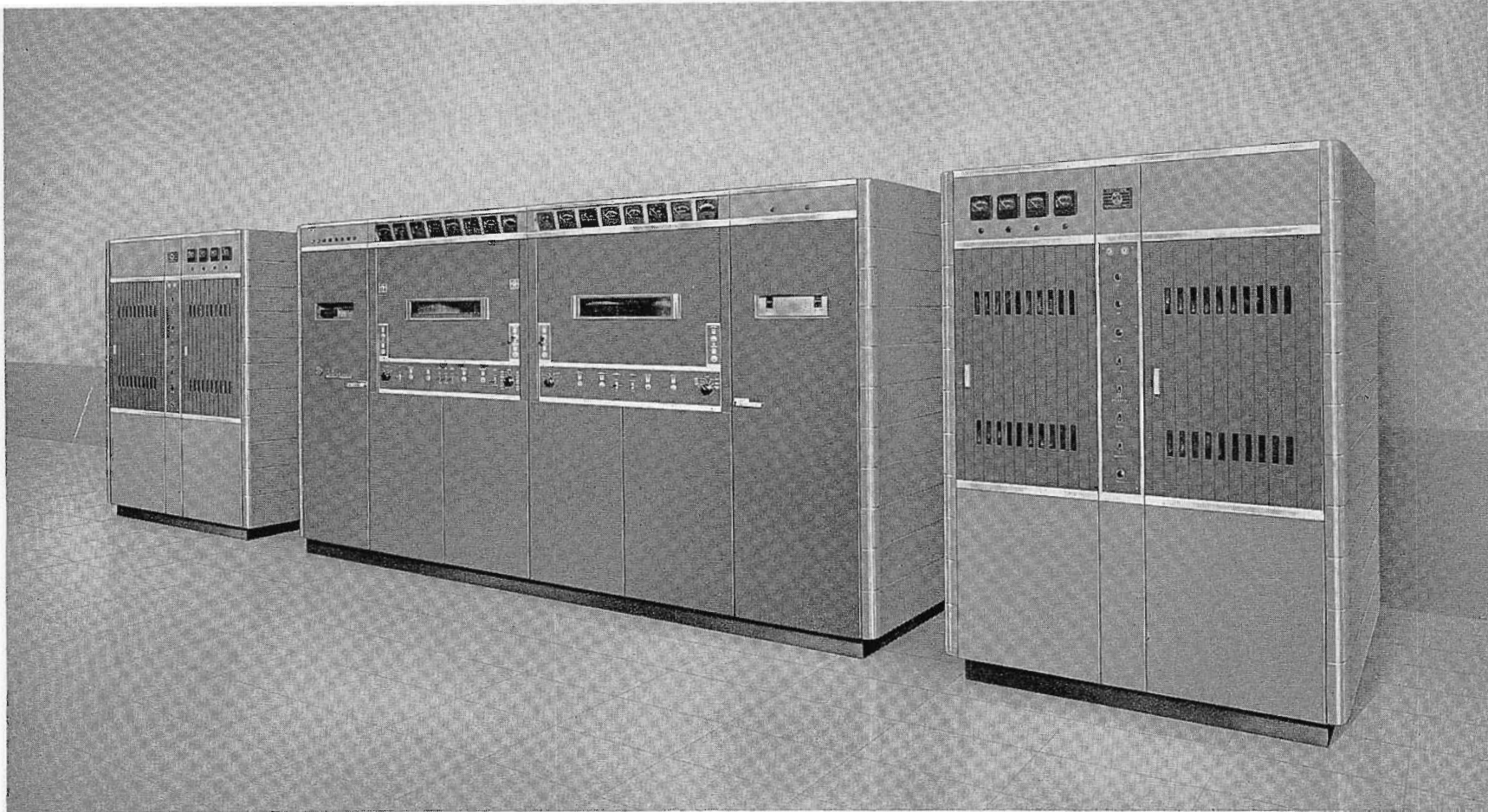

FIG. 1. RCA 25-kw Television Transmitter, Type TT-25CH. The visual control and rectifier cubicles are on the right, the aural are on the left. The TT-11AH driver is in the center. These three units may be arranged in any convenient manner within existing buildings.

# NEW 25-KW HIGH-BAND TELEVISION TRANSMITTER

*Type TT-25CH is an Ideal High-Power Unit for Achieving Maximum ERP with Minimum of Floor Space*

by DONALD R. MASON, *Broadcast and Television Equipment*

The TT-25CH Television Transmitter operates on VHF channels 7 through 13, with a peak visual power output of 25 kw. When used with one of the current VHF antennas, it is possible to obtain the maximum allowable 316,000 watts effective radiated power. The TT-25CH may be purchased as a complete 25-kw high-power unit, or may be the result of a building-block program starting with a 2-kw transmitter (TT-2BH), then adding an 11-kw amplifier (TT-11AH), and finally adding the 25-kw amplifiers. A minimum of conversion is necessary to change from one power level to the next as the station grows.

## Design Features

The TT-25CH was designed with reliability and ease of operation and maintenance in mind. Access to components is better because of new improved mechanical design. Space requirements have been reduced as much as 30 per cent over previous designs to allow for installation in existing buildings. Reduction of required floor space is effected by a walk-in enclosure design of the driver portion of the TT-25CH (see Fig. 2).

This type of construction eliminates the need for external access space at the rear of the enclosure. The enclosure may be

placed directly against a wall or even in a corner of the room if an air intake opening is provided. Access to all components of the driver is possible from within the enclosure. The modulator and exciter may be serviced by tilting the chassis forward, without removal from the cabinet (see Fig. 3).

Where space is at an extreme premium, it is possible to locate the rectifier equipment in a basement room by using a separate rectifier enclosure, as optional equipment. Figure 4 shows one of many possible floor plans to which the TT-25CH may be adapted.

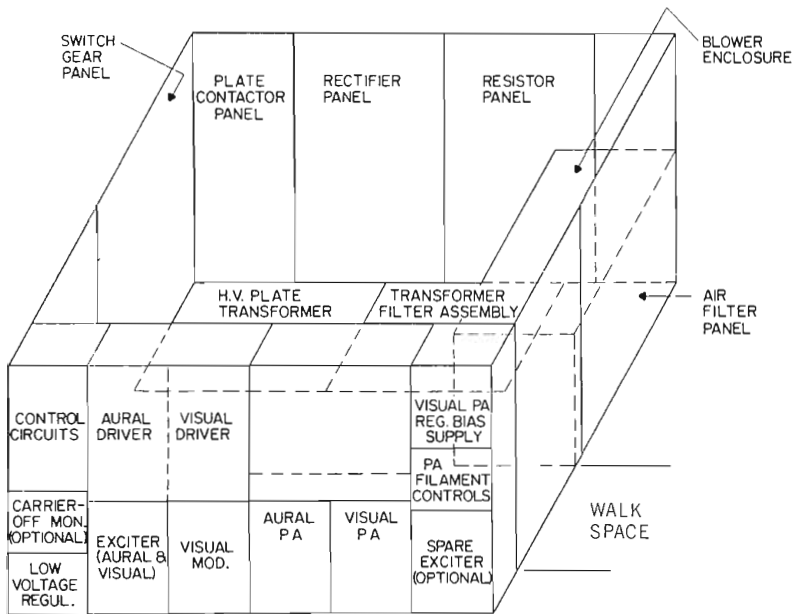

FIG. 2. Walk-in type construction of the driver permits easy servicing. Rectifiers and cooling equipment are at the rear of the enclosure. The remaining portions of the driver are in the front line of cabinets.

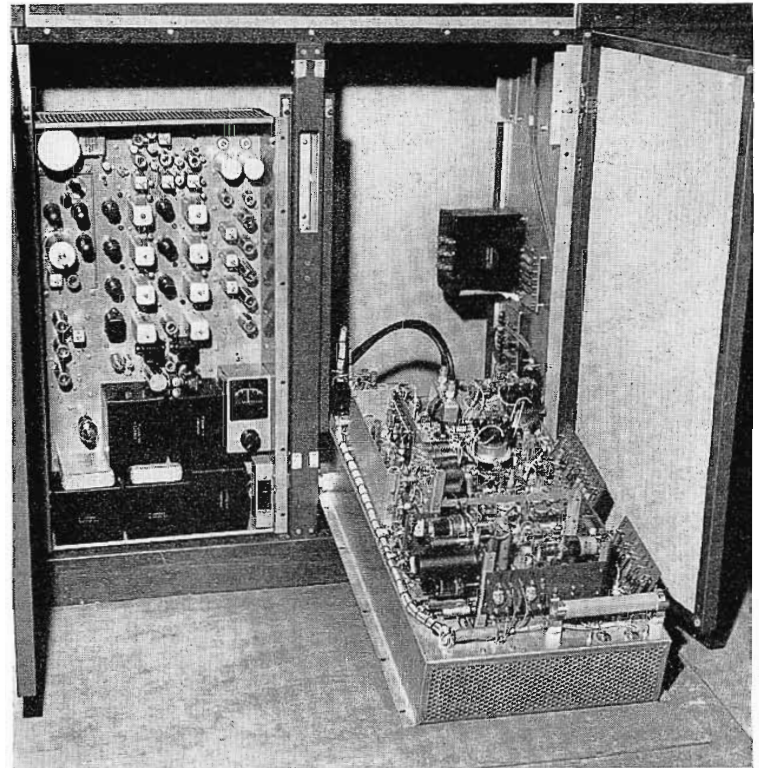

FIG. 3. The visual modulator is tilted out for servicing. The aural-visual exciter is shown in its normal position on the left.

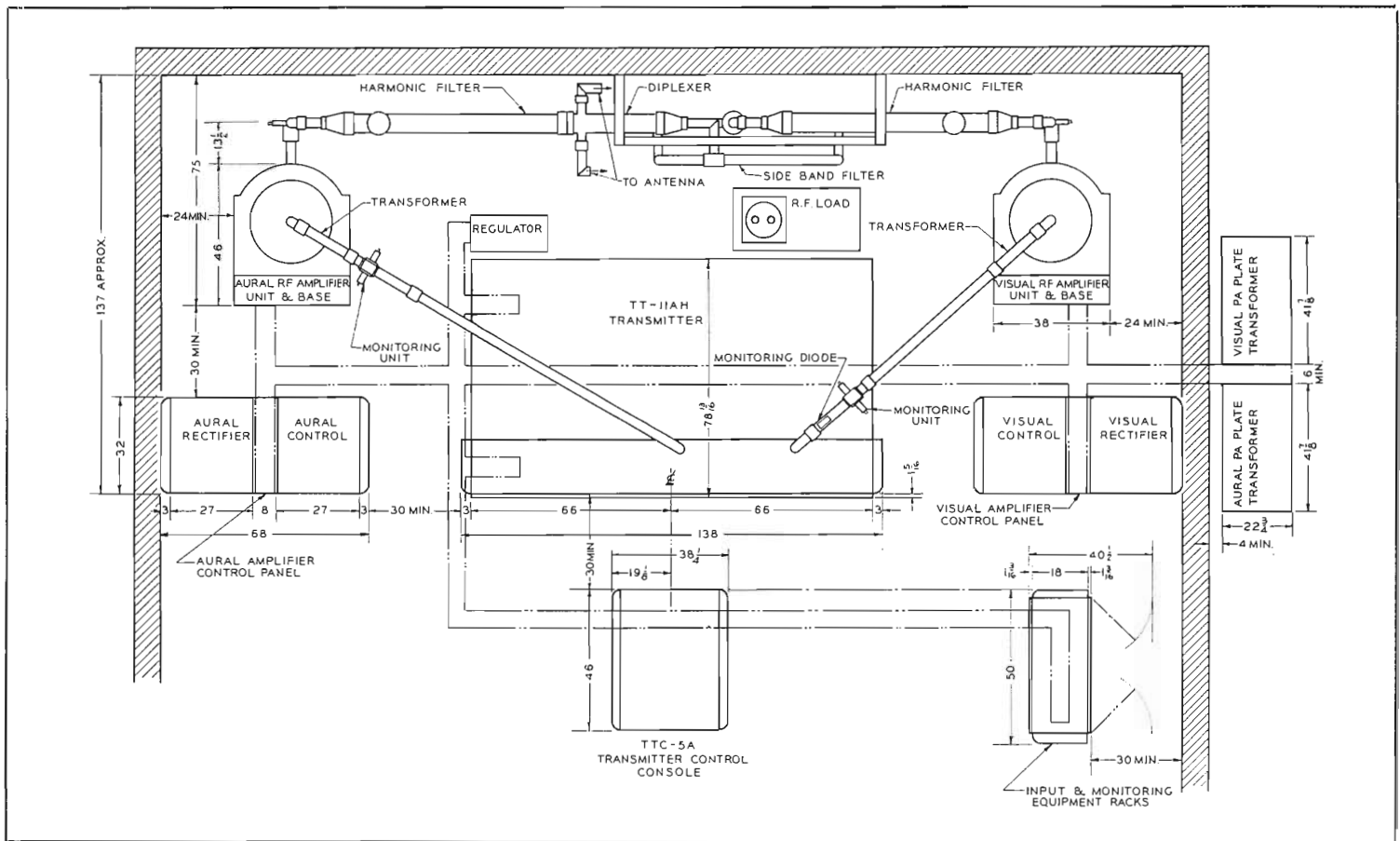

FIG. 4. Typical floor plan for the TT-25CH Transmitter. Many variations of this floor plan are possible to meet requirements of existing buildings.

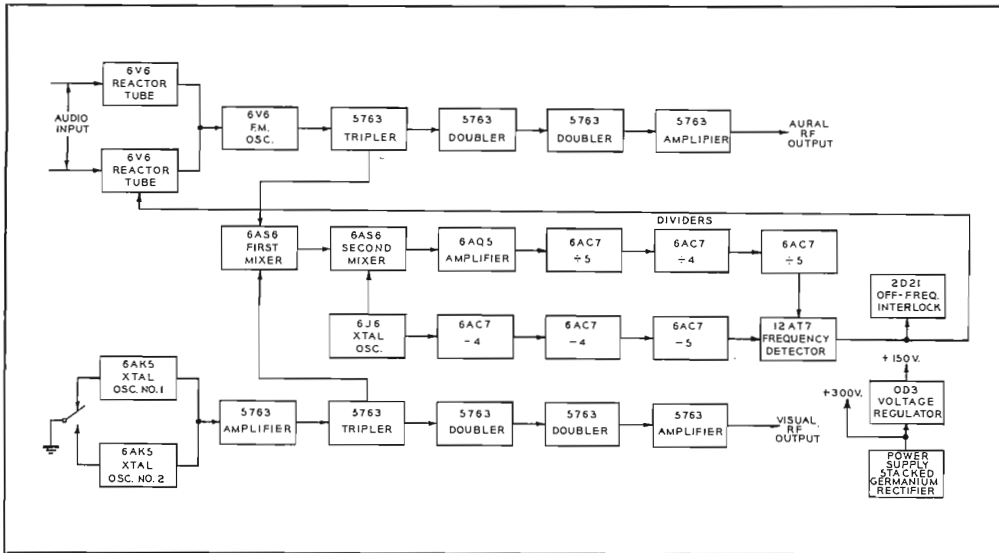

FIG. 5. Block diagram of the high band aural-visual exciter used in the TT-2BH, TT-11AH, and the TT-25CH. Automatic 4.5 mc separation is maintained between the aural and visual carriers with the novel frequency control circuit used in this exciter.

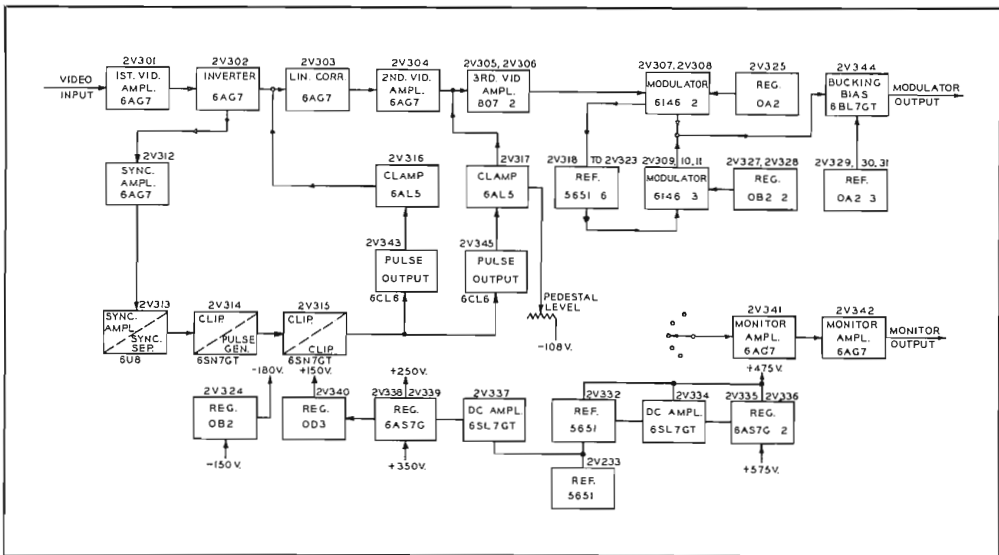

FIG. 6. Block diagram of the visual modulator stage of the TT-11AH driver. The modulator supplies a 250-volt peak-to-peak signal that grid modulates the 6076 visual modulator amplifier. Built-in linearity correction compensates for non-linearity, which occurs in a grid modulated stage.

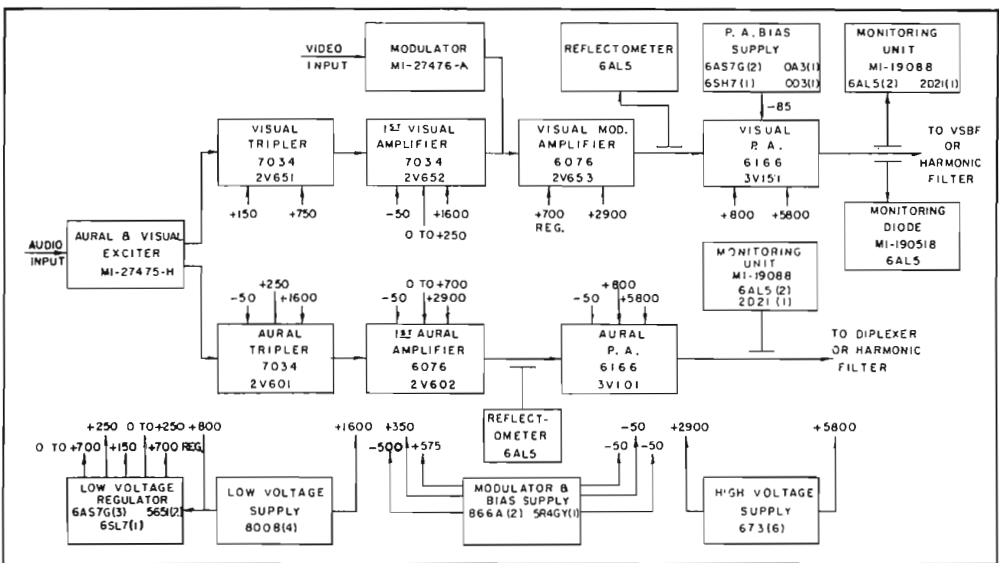

FIG. 7. Complete block diagram of the TT-25CH, illustrating the simplified circuitry.

Use of the completely self-contained TT-11AH as a driver provides for fast cutback to the driver in case of amplifier or antenna system problems which may require temporary reduction of power.

### Standardized Aural-Visual Exciter

A block diagram of the aural/visual exciter is shown in Fig. 5. Both the aural and visual carriers are locked to a single crystal. Carrier separation, well within FCC specifications, is automatically adjusted by frequency control circuitry.

A block diagram of the video modulator is shown in Fig. 6. The modulator output is used to grid modulate a type 6076 tetrode operating at a nominal 2-kw peak visual power (see Fig. 7). All R. F. stages preceding this are operated as regular class "C" amplifiers.

### Grounded-Grid Drivers

The visual linear amplifier following the modulated stage employs a 6166 tetrode in a grounded grid, grounded screen circuit. This type of operation is used in the RCA 50-kw television transmitter, and it is extremely stable. Circuit design is simplified, since the grid and screen may be by-passed to a common ground plane. Input and output circuits are then constructed on opposite sides of the ground plane. The newly designed 6166 cavity is fabricated in rectangular shape so that removal of one panel exposes the entire cavity for cleaning or preventative maintenance. No neutralizing adjustments are required, since the 6166 stage is effectively neutralized over the entire band. DC is used for the filaments of the 6166 to reduce hum modulation to a level where it is not noticeable in the picture. A similar tube complement is used for the aural signal as indicated in Fig. 7.

### High Power PA Amplifiers

Each 6166 stage, aural and visual, drives an amplifier using seven 5762 tubes paralleled in a grounded grid circuit to produce outputs of 25-kw peak visual power and 14-kw aural power. Figures 8 and 9 show the mechanical construction of the 25-kw amplifier, and Fig. 10 shows an equivalent circuit.

Two coaxial tank circuits are employed with one of these tanks placed inside the other. These function as parallel inductances, thus raising the effective resonant frequency. The output is coupled to the inner of these plate tank circuits across a shunt inductance. To preserve the cir-

circuit symmetry, this inductance is actually made up of seven small adjustable shorted transmission lines connected in parallel and located on a circle just inside the inner plate tank. The output circuit is formed by inserting a shunt capacitor in the output transmission line, and is tuned by sliding this capacitor along the line. Because the two circuits are at a low impedance point, the capacitor is located approximately one-half wave length along the line. This secondary circuit, coupled to the plate circuit by means of a mutual reactance, forms the necessary elements of an over-coupled broadband circuit with a band pass essentially flat over six megacycles.

The cathode circuit cannot be made a conventional quarter wave tank because the first low impedance point would occur at the tube straps. To compensate for this extra inductance of the straps, coaxial capacitors are connected in series with the tube leads. The capacitors are variable, and when mechanically ganged become the input tuning control. This cathode circuit is matched to the 51.5 ohm input from the 6166 driver, by two quarter-wave transformers in series. Input coupling is provided by making one of these transformers variable in characteristic impedance as the

outer shell is rotated through 90 degrees. With few exceptions, identical components are used for aural and visual circuits throughout the TT-25CH transmitter. It is therefore possible to reduce spare tube and parts inventory as much as 50 per cent.

### Complete Protection

Extensive metering and protective circuits are provided. A supervisory overload circuit indicates the circuit in which an overload occurs. Monitoring units, which continuously monitor standing wave ratio in the output lines are included as standard equipment. If the reflected power rises above a predetermined level, the transmitter is automatically turned off to prevent damage.

### Added Reliability

Tubes, components, and designs used in the TT-25CH have been carefully chosen to provide at a nominal cost, a high-power VHF transmitter with the same reliability for which RCA television transmitters have long been famous. Thus, the TT-25CH is a TV transmitter that will be satisfactory for new installations, plant modernization, and power increases. It offers a simplified and economical means of achieving maximum ERP.

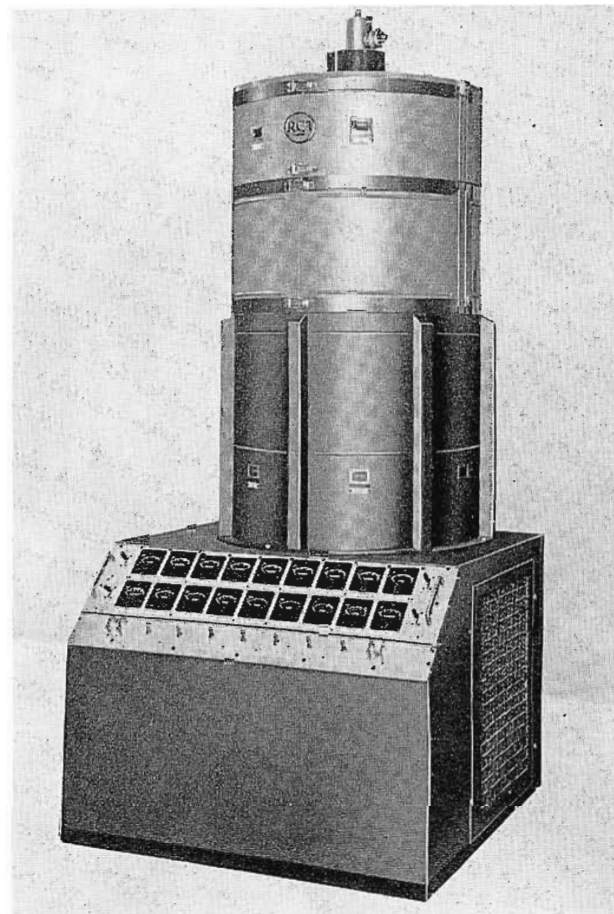

FIG. 8. External view of the TT-25CH amplifier. Note the extensive metering facilities, which indicate all important circuit conditions.

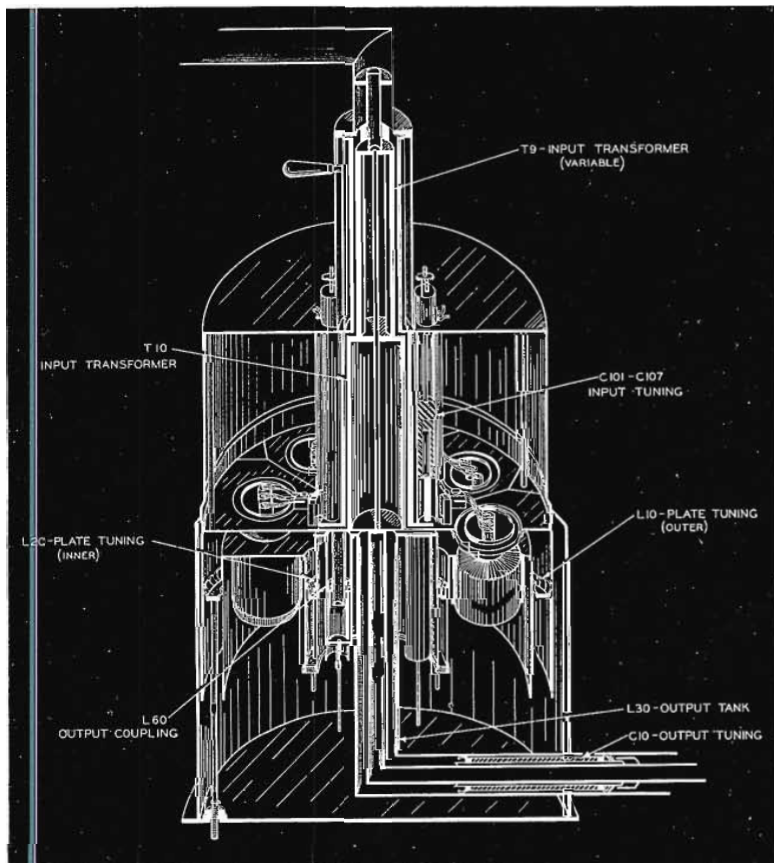
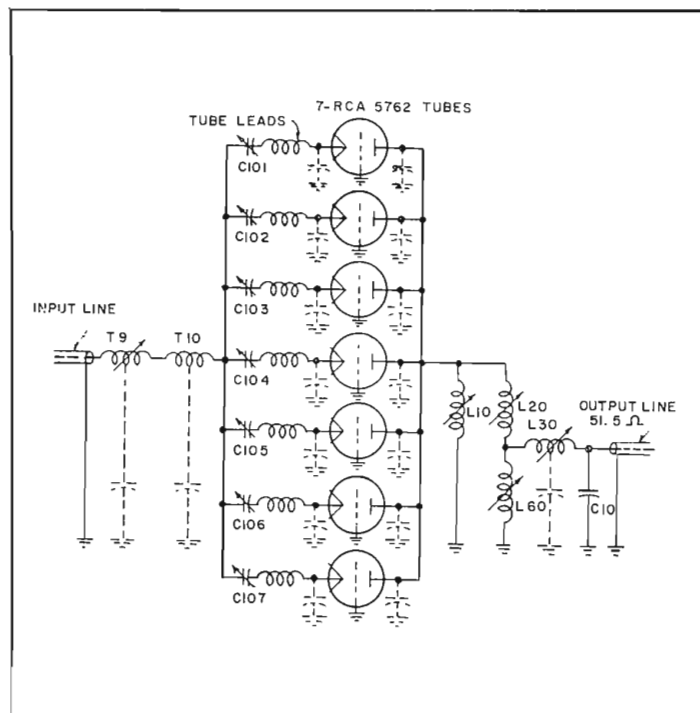

FIG. 9. This cut-away drawing shows the mechanical construction of the 25-kw amplifier used in the TT-25CH. Two coaxial tank circuits are used, one placed inside the other. They function as parallel inductances to raise the effective resonant frequency of the circuit. Output tuning is accomplished by the shunt capacitor in the output transmission line.

FIG. 10. The equivalent circuit 25-kw amplifier is shown here. The dotted lines indicate distributed capacity of leads and components used. Seven RCA Type 5762 tubes operating with grounded grids are used to produce the 25-kw output signal.



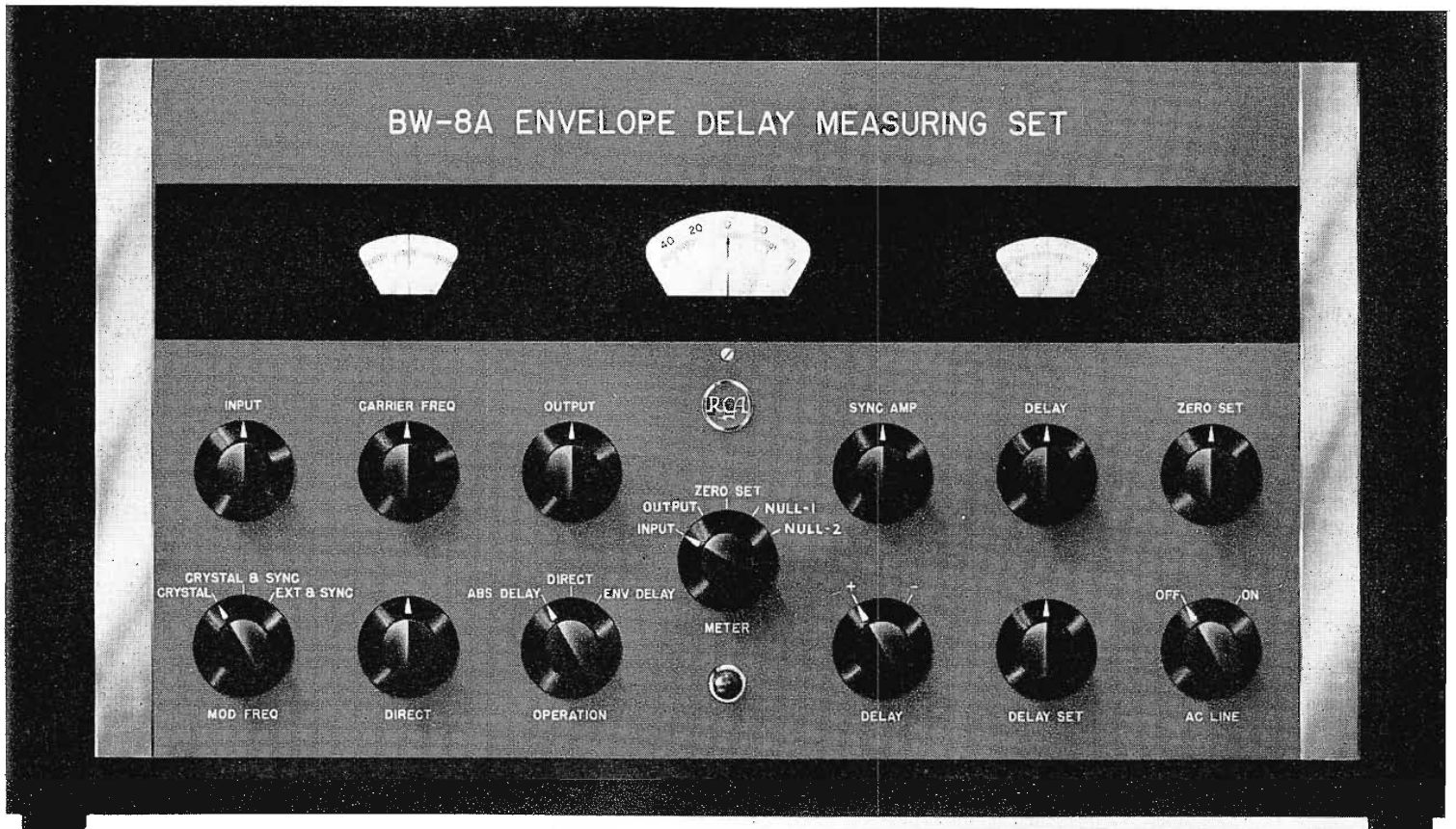

FIG. 1. This is the Envelope Delay Measuring Set, Type BW-8A. All operating controls have been placed on the front panel of this direct reading equipment.

# PORTABLE ENVELOPE-DELAY MEASURING EQUIPMENT

*New Technique Makes Possible Accurate Measurement of  
Color Subcarrier Transmission Time Phase Delay in the Field*

*by JUAN C. CHIABRANDO, Broadcast and Television Engineering*

To the present time, accurate measurements of color subcarrier envelope delay have been made only in the laboratory, using highly specialized and rather elaborate measuring gear. The FCC has waived measurements of envelope delay for station proof of performance due to the lack of suitable field-measuring equipment. The Type BW-8A Envelope Delay Measuring Set is designed to fill this pressing need.

It is a practical and accurate device to measure the phase response of the transmitter, so that proper phase compensation may be introduced in the station's video phase equalizers.

## **Delay Requirements**

In color TV systems, the coincidence of arrival of chrominance and luminance information must be kept within close toler-



ances to avoid picture degradation. The chrominance information is transmitted by amplitude modulating two components of the color subcarrier. These components are 90 degrees out of phase with each other, and their relative phase must be preserved, since a phase shift will produce a change in color.

In order to maintain conditions for a good quality color picture, the FCC specifications for a color television signal states the "Delay Specifications" as follows:

*"A sine wave, introduced at those terminals of the transmitter which are normally fed the composite color picture signal, shall produce a radiated signal having an envelope delay, relative to the average envelope delay between 0.05 and 0.20 mc, of zero*

*microseconds up to a frequency of 3.0 mc; and then linearly decreasing to 4.18 mc so as to be equal to -0.17  $\mu$ s at 3.58 mc. The tolerance on the envelope delay shall be  $\pm 0.05 \mu$ s at 3.58 mc. The tolerance shall increase linearly to  $\pm 0.1 \mu$ s down to 2.1 mc, and remain at  $\pm 0.1 \mu$ s down to 0.2 mc. The tolerance shall also increase linearly to  $\pm 0.1 \mu$ s at 4.18 mc."*

Actually, this specification for the color TV radiated signal includes a predistortion in order to compensate for the delay characteristics of a "typical" color receiver. A monochrome TV system that complies with these specifications would yield a high-quality picture; so that the benefits of proper control of envelope delay is not restricted to color TV.

### System Relationships

The phase angle and time delay are related by:

$$\beta = 2\pi ft \quad \text{where: } t = \text{Time Delay}$$

$$\beta = \text{Phase Angle}$$

$$f = \text{Signal Frequency}$$

$$\text{then: } t = \frac{\beta}{2\pi f}$$

If the time delay is constant within the desired band, the phase angle will increase linearly with frequency.

A more sensitive way to specify the phase characteristics of a system is by the slope of the phase vs frequency curve, called "envelope delay" ( $t_e$ ):

$$t_e = \frac{d\beta}{df}$$

This is the criteria proposed by NTSC and adopted by FCC.

FIG. 2. Block diagram of the BW-8A Envelope Delay Measuring Set. The operation switch ( $S_2$ ) controls the path of the test signal: Positions 1 and 3 are similar; however, when set in position 3 the  $F_A$  signal passes through the network while in position 1 the  $F_A$  signal is not delayed by the network. Position 2 bypasses the network under test and feeds the signal directly into the receiver. The calibrated phase shifter provides direct reading of the phase difference between the two signals.

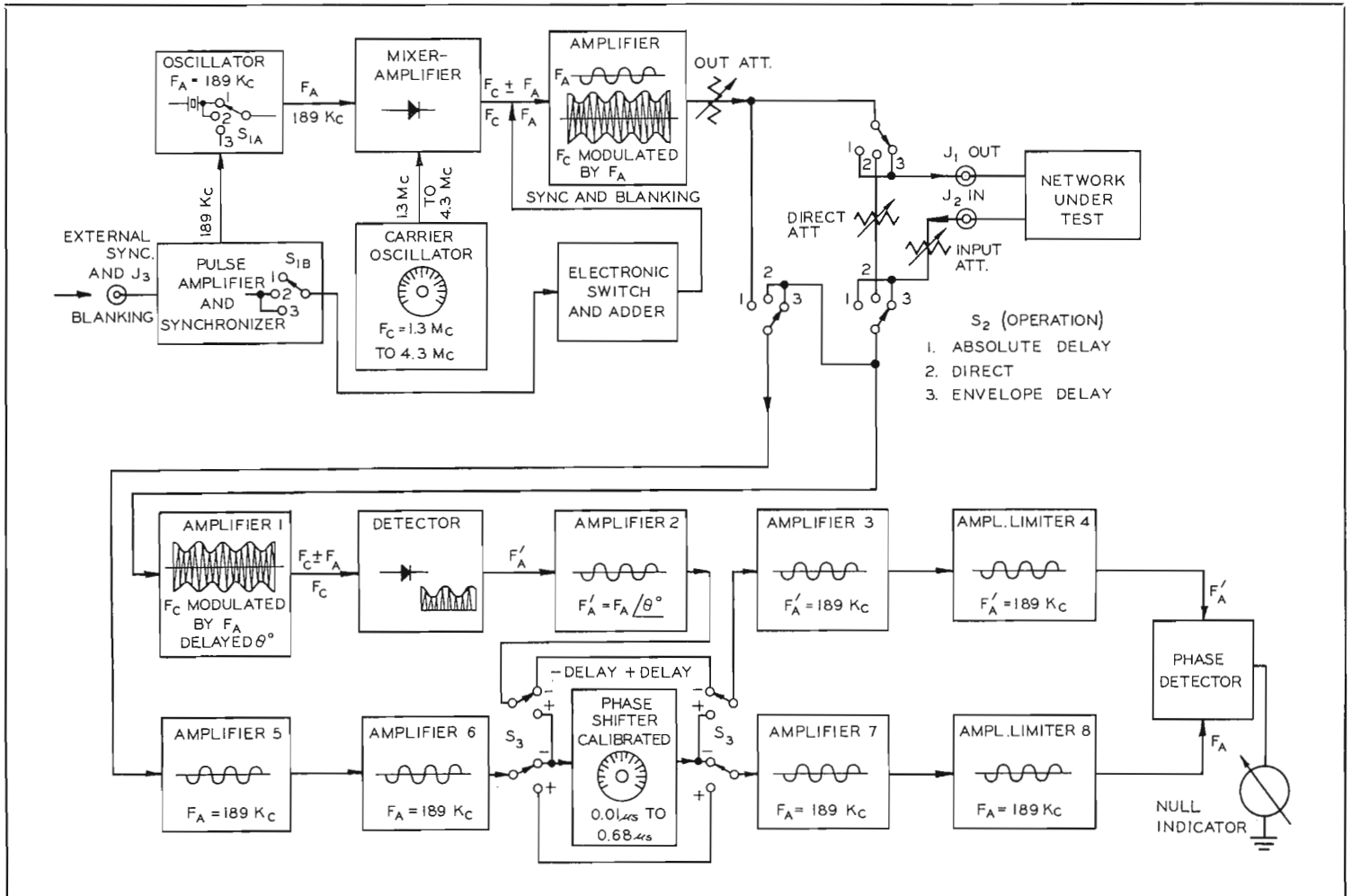

## Two-Tone Means of Measurement

The definition of envelope delay suggests a method of measuring, using two signals ( $f_1$ ,  $f_2$ ) whose difference in frequency is such that  $\Delta f = f_2 - f_1$ .

The envelope delay can be determined by measuring phase difference of the two signals after passing through the network to be measured:

$$\text{Then: } t_c = \frac{\beta_2 - \beta_1}{\Delta f} = \frac{\Delta \beta}{\Delta f}$$

Where:  $\beta_1$  = phase angle of  $f_1$  after passing through the unknown  
 $\beta_2$  = phase angle of  $f_2$  after passing through the unknown

This method can be used in a direct display system, where  $f_1$  and  $f_2$  are swept across the desired frequency range, maintaining  $\Delta f$  constant, and displaying  $\Delta \beta$  as a function of  $f$ . The envelope delay will be directly proportional to  $\Delta \beta$ .

The main limitation of this "two tone" method is that it does not compare the values of envelope delay with the average envelope delay at the lower frequency end of the video band, as required by FCC.

## Practical Measuring Method

A second means of measuring envelope delay is based on the following facts:

1. For a band extending from dc to a frequency  $f_a$ , phase delay at  $f_a$  is equal to average envelope delay between dc and  $f_a$ , when all frequencies within this band are taken with constant weight.
2. For a carrier  $f_c$ , amplitude modulated by  $f_b$ , phase of the sidebands envelope is equivalent to average envelope delay in the interval  $f_c \pm f_b$ .

Applying these principles, and making  $f_b = f_a$ , the envelope delay measuring set generates a test signal composed of  $f_a$  plus the modulated carrier  $f_c \pm f_b$ .

This signal passes through network to be measured and is fed back to receiver section of measuring set, where the two components are separated and processed. An envelope detector recovers  $f_b$ , then phase difference between  $f_a$  and  $f_b$  is measured and this is equivalent to value of average envelope delay in band  $f_c \pm f_b$ , as compared with average envelope delay from dc to  $f_a$ . The carrier frequency  $f_c$  can be made variable, from high end of the video band to a lower practical limit:  $f_c >$  or equal to  $5 f_a$ .

Advantages of this second method are:

1. By choosing  $f_a$  in vicinity of 0.2 mc this method will give relative values of envelope delay in a manner very similar to that specified by FCC.
2. By incorporating horizontal sync and blanking in test signal it is possible to measure envelope delay in TV modulators and other equipment which include clamp circuits.
3. A practical version can be made portable and easy to operate.
4. This method does not measure the envelope delay in part of lower middle range of video band, from  $f_a$  to  $f_c - f_a$  but unlike two-tone method it does, inherently, have a low-frequency reference which is the average envelope delay between 0 and 189 kc.

## Portable Measuring Equipment

Figure 2 shows a block diagram of the Type BW-8A Envelope Delay Measuring Set. The fixed frequency  $F_a = 189$  kc has been chosen as the twelfth harmonic of the horizontal sync of a standard television signal; it can be obtained from the crystal-controlled oscillator, or it can be derived from the external source of horizontal sync signal required to incorporate sync and blanking in the test signal.

Switch  $S_1$  selects source of  $F_a$  and controls addition of sync and blanking to output test signal. Position 1 corresponds to crystal-controlled, 189-kc signal and does not incorporate sync and blanking in test signal. Position 2 adds sync and blanking while maintaining crystal oscillator for  $F_a$ . Position 3 derives  $F_a$  from external sync and incorporates sync and blanking in test signal. When operating in position 2, accuracy of envelope delay measurements is somewhat decreased, so it should only be used when sync and blanking in test signal are required, but external source of sync is not crystal controlled.

The variable frequency carrier oscillator covers the band from 1.3 mc to 4.3 mc in a single range; it is tuned by means of a variable inductance and is gang coupled with tuned circuits of mixer-amplifier and first amplifier in receiver section.

The plate load of the mixer amplifier is composed of a series of two tuned circuits resonating at  $F_a$  and  $F_c$ ; the second one being permeability tuned and shunted with a constant load resistor,  $R_p$ .

$$\text{Thus: } Q = \frac{R_p}{\omega L} = R_p \omega C$$

$Q$  increases with frequency and tends to maintain a constant bandwidth. In this

case the attenuation is less than 1 db for  $\Delta F = 189$  kc, at any carrier frequency.

The electronic switch and adder incorporates sync and blanking in the test signal whenever switch  $S_1$  is in position 2 or 3.

The output amplifier of the generator section is a cathode follower that can deliver more than 2 volts peak-to-peak of test signal into a 75-ohm load.

The operation switch,  $S_2$ , controls path of test signal from generator to receiver section; when in position 2, signal is fed directly to receiver. In position 3, signal passes through network under test before reaching receiver. Position 1 is similar to 3 but  $F_a$  signal for fifth amplifier is fed directly from output of generator, so it appears undelayed regardless of characteristics of network under test. The "Input" connector is internally loaded with a 75-ohm terminating resistor.

The receiver section is composed of two chains. Amplifier one is tuned to  $F_c$ , its plate-tuned circuit is mechanically coupled to carrier oscillator and mixer circuits in generator section. A diode envelope detector following first amplifier recovers modulating signal  $F'_a$ . This signal differs from  $F_a$  in phase angle  $\theta$ , to be determined. This chain is completed with three amplifiers tuned to  $F_a$ ; the last one being a limiter that feeds a constant amplitude signal to the phase detector. The second chain is composed of four amplifiers tuned to  $F_a$ . The last amplifier is a limiter.

Figure 3 shows schematic of phase detector—its principle of operation being similar to an FM discriminator. The output consists of a dc voltage proportional to phase difference of signals fed from amplifiers number 4 and 8. A VTVM connected to a 5-position switch performs several measuring functions: Position 2 measures peak amplitude of output test signal fed to the unknown network. Position 1 measures peak of signal at input of receiver. Position 3 is for balancing the VTVM. Positions 4 and 5 are for use as null indicator for phase detector, four being of lower sensitivity in order to start balancing of phase detector.

The phase shifter is an RLC network—its delay at 189 kc is varied by means of a precision 3-turn potentiometer. By means of switch  $S_3$ , the phase shifter network can be introduced in either one of the two chains, allowing compensation of positive or negative phase delay.

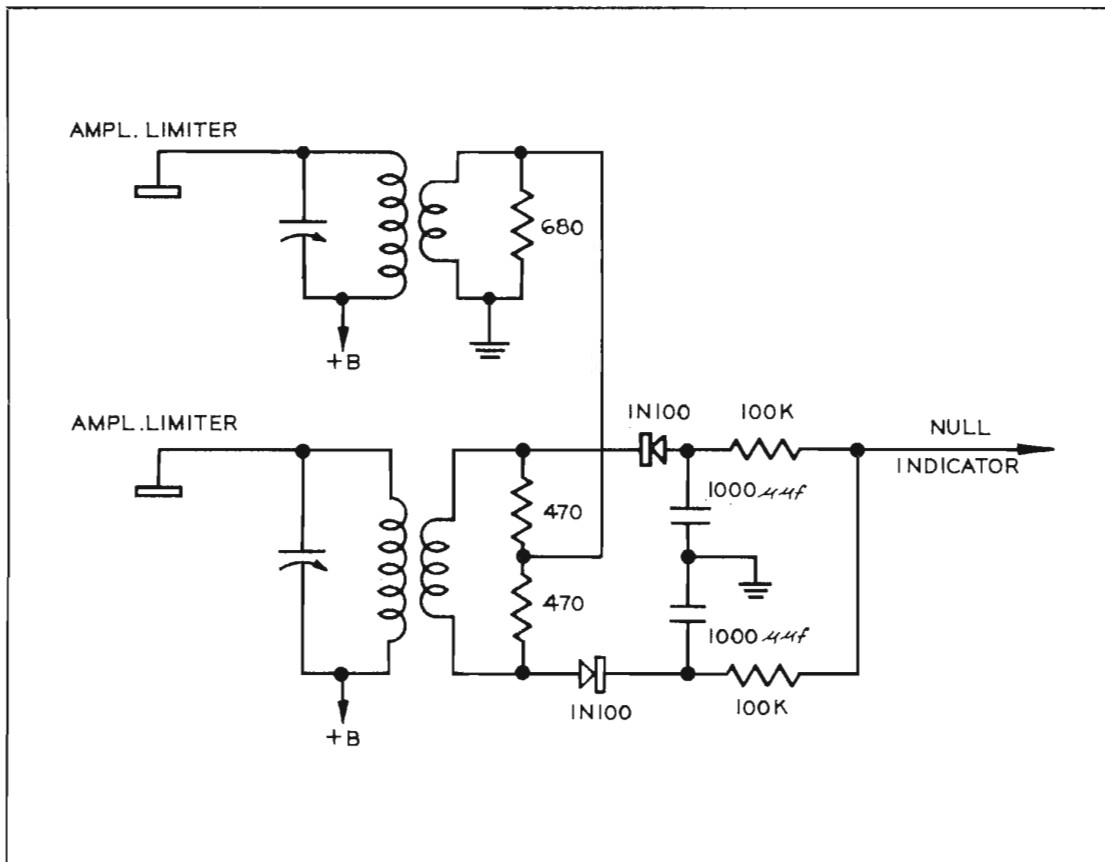

FIG. 3. The phase detector circuit of the BW-8A is shown here. The output is a d-c voltage proportional to the phase difference between the two amplifier signals.

### Convenient Portable Unit

All the controls are located on the front panel, those of the generator being on the left side and those of the receiver on the right. The output and input connectors, as well as the external sync input, the power connector and the fuse holder, are located on the rear of the chassis. The dial on the left side controls the carrier frequency and is directly calibrated from 1.3 to 4.3 mc (see Fig. 1). The dial on the right drives a precision 3-turn potentiometer that controls the phase shifter; this dial is calibrated in delay, from 0.01 to 0.67  $\mu$ s.

Other controls located on the front panel but not shown in the block diagram are: ac line switch; "Sync Amplitude" that regulates amount of sync incorporated in test signal; "Zero Set," used to balance the VTVM when its switch is in position three; "Delay Set," used to balance delay of measuring set when operation switch,  $S_2$ , is in "Direct" position. The electronically regulated power supply is built on the rear of the chassis, the generator section is built on the left, and the receiver on the right.

### Selection of Test Frequency

The type of test signal desired is selected by means of "Mod Freq" switch. Position 1 is used when measuring TV equipment that can be fed with a sinusoidal signal without sync and blanking, as an RCA video modulator or TV transmitter. When measuring a unit whose circuit includes clampers, a suitable test signal is obtained by turning the switch to positions 3 or 2. In this case an external source of sync and blanking is required.

The amplitude of the test signal fed to the equipment under test can be adjusted up to 2 volts peak-to-peak; it will remain constant  $\pm 1$  db throughout the frequency range.

The output of the unknown is then fed to the receiver input and can vary as much as  $\pm 4$  db from 1.3 mc to 4.3 mc without requiring any adjustment of "Input" control. Larger variations could fall out of the limiting range of limiters and the "Input" control should be used to compensate for them.

A direct reading dial controls the carrier frequency. Once it is set and before making delay measurements, the delay inherent

in measuring set is balanced out by means of "Delay Set" control. This is done having "Operation" switch in direct position.

The "Meter" switch has two positions for balance, labeled Null 1 and Null 2; the first (1) being of lower sensitivity in order to balance.

To measure absolute Delay or Envelope Delay, "Operation" switch is turned to appropriate position and balance is restored by means of "Delay" dial and plus or minus "Delay" switch. Thus the magnitude and sign of the delay are obtained by direct reading with an accuracy of  $\pm 3$  percent ( $\pm 0.01 \mu$ s).

### Auxiliary Equipment

When measuring a video amplifier or any other equipment having input and output at video frequencies, no auxiliary equipment is required. When a complete transmitter is being measured the only auxiliary unit required is an rf demodulator to feed video signal to receiver portion of the BW-8A. If equipment under test requires a signal with sync and blanking, this can be obtained from a studio sync generator. The BW-8A will operate satisfactorily when fed with a standard TV "white" signal.

# PATTERN SYNTHESIS<sup>1</sup>

## Simplified Methods of Array Design to Obtain A Desired Directive Pattern for AM Antennas

by GEORGE H. BROWN, Vice President, Engineering, Radio Corporation of America, Princeton, New Jersey

This article describes the mathematical methods for determining the magnitude and phase of current distribution over an extended linear antenna aperture, in order to obtain a desired directive radiation pattern. It is shown that the radiation pattern and the current distribution form a set of Fourier Transforms, thus yielding a ready solution to the problem. By adding a pattern in an imaginary zone to the desired real pattern, many current distributions or array configurations are found, all of which give the same desired pattern in the real zone.

### 1. Introduction

During the war, the writer and his colleagues were many times confronted with the task of designing large-aperture antennas to produce critically shaped beams with minimum side lobes and with specific rates-of-change of the main beam. The work of Dr. Irving Wolff<sup>2</sup> in applying Fourier series to relate the radiation pattern to a linear array of point sources of radiation led to the infinite Fourier integral. This yielded a ready solution of many problems by forming a set of Fourier Transforms to relate the desired directive pattern and the necessary current distribution.

P. M. Woodward<sup>3</sup> has published a powerful method of dealing with the problem, in which he combines graphical and analytical methods. Careful reading of his paper reveals that he was fully aware of the Fourier integral relationship and that he realized the value of sometimes proceeding into the imaginary angular domain. It is felt that this article may supplement his exposition and assist in clarifying some of the obscure points.

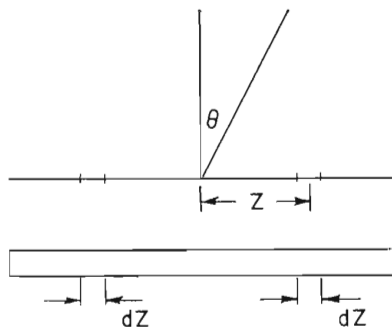

FIG. 1. A radiating current sheet.

### II. Field Intensity When Current Distribution is an Even Function

When the currents in an array are specified as to magnitude and phase angle, the calculation of the resulting radiation pattern is not usually a very complicated operation. The converse operation, that of specifying the field pattern and then determining the current distribution, is quite another problem.

In Fig. 1, we have a sheet of current with the current distributed symmetrically about the center as an even function, that is,  $i(z) = i(-z)$ . The field due to the two small current elements shown in Fig. 1 is:

$$dE = 2Ki(z) \cos\left(\frac{2\pi z}{\lambda} \sin \theta\right) dz \quad (1)$$

where  $i(z)$  is the current per unit width. The current at all points in the sheet is of constant phase.

The total field due to the entire sheet is:

$$E(\theta) = 2K \int_{z=0}^{z=\frac{W}{2}} i(z) \cos\left(\frac{2\pi z}{\lambda} \sin \theta\right) dz \quad (2)$$

where the sheet is of width  $W$ . Equation (2) may be written as:

$$E(\theta) = 2K \int_{z=0}^{z=\infty} i(z) \cos\left(\frac{2\pi z}{\lambda} \sin \theta\right) dz \quad (3)$$

with the understanding that  $i(z)$  in the integral is zero when  $z$  has a value greater than half the width of the sheet.

We are, in general, interested in the field variation over a range of angles from  $\theta = -90^\circ$  to  $\theta = 90^\circ$ . Thus if we substitute  $x = \sin \theta$ , we will be interested in the field in the interval between  $x = -1$  and  $x = 1$ . Then (3) becomes:

$$E(x) = 2K \int_{z=0}^{z=\infty} i(z) \cos\left(\frac{2\pi z}{\lambda} \cdot x\right) dz \quad (4)$$

Now in (4) let us substitute a new variable,  $v = 2\pi z/\lambda$ :

$$E(x) = \frac{\lambda}{\pi} K \int_{v=0}^{v=\infty} \cos(vx) dv \cdot i(v) \quad (5)$$

It is readily seen that in this case where we have chosen  $i(v)$  to be an even function of  $v$ ,  $E(x)$  is constrained to be an even function of  $x$ .

<sup>1</sup> This was presented at the NAB Convention, Chicago, Ill., March, 1959.

<sup>2</sup> Irving Wolff, "Determination Of The Radiating System Which Will Produce A Specified Directional Characteristic," *Proc. I.R.E.*, Vol. 25, No. 5, pp. 630-643; May, 1937.

<sup>3</sup> P. M. Woodward, "A Method Of Calculating The Field Over a Plane Aperture Required To Produce A Given Polar Diagram," *Journal of The Institution of Electrical Engineers*, Vol. 93, Part IIIA, No. 10, pp. 1554-1558; March-May, 1946.

### III. Field Intensity When Current Distribution is an Odd Function

Let us now consider an arrangement where we have negative symmetry in the current distribution. Then the current distribution is an odd function of  $z$  and  $i(z) = -i(-z)$ . In addition,  $i(z)$  is constant in phase for all values of  $z$ . The field intensity distribution is then:

$$E(x) = j \frac{\lambda}{\pi} K \int_{v=0}^{v=\infty} \sin(vx) dv \cdot i(v) \quad (6)$$

It is seen that  $E(x)$  is an odd function of  $x$ . In addition,  $E(x)$  leads the current distribution,  $i(v)$ , by 90 degrees.

### IV. Fourier Integral Relationship

A single-valued continuous function,  $E(x)$ , that exists in the interval from  $x = -\infty$  to  $x = +\infty$  may be expressed in terms of the infinite Fourier integral:

$$\begin{aligned} E(x) &= \frac{1}{2\pi} \int_{\beta=-\infty}^{\beta=\infty} E(\beta) d\beta \int_{v=-\infty}^{v=\infty} \cos v(\beta-x) dv \\ &= \frac{1}{2\pi} \int_{\beta=-\infty}^{\beta=\infty} E(\beta) d\beta \left[ \int_{v=-\infty}^{v=\infty} \cos(v\beta) \cos(vx) dv + \int_{v=-\infty}^{v=\infty} \sin(v\beta) \sin(vx) dv \right] \end{aligned} \quad (7)$$

If  $E(x)$  is an even function, that is,  $E(x) = E(-x)$ , the last term in (7) disappears and  $E(x)$  is given by:

$$\begin{aligned} E(x) &= \frac{2}{\pi} \int_{\beta=0}^{\beta=\infty} E(\beta) d\beta \int_{v=0}^{v=\infty} \cos(v\beta) \cos(vx) dv \\ &= \frac{2}{\pi} \int_{v=0}^{v=\infty} \cos(vx) dv \int_{\beta=0}^{\beta=\infty} E(\beta) \cos(v\beta) d\beta \end{aligned} \quad (8)$$

Then equating (5) and (8):

$$\frac{\lambda}{2} Ki(v) = \int_{\beta=0}^{\beta=\infty} E(\beta) \cos(v\beta) d\beta \quad (9)$$

Thus, if  $E(x)$  is an even function, (9) gives the necessary current distribution to produce the desired field distribution.

When  $E(x)$  is an odd function, that is,  $E(x) = -E(-x)$ , the first term in (7) vanishes and  $E(x)$  is:

$$E(x) = \frac{2}{\pi} \int_{v=0}^{v=\infty} \sin(vx) dv \int_{\beta=0}^{\beta=\infty} E(\beta) \sin(v\beta) d\beta \quad (10)$$

Equating (6) and (8), we find:

$$j \frac{\lambda}{2} Ki(v) = \int_{\beta=0}^{\beta=\infty} E(\beta) \sin(v\beta) d\beta \quad (11)$$

So, if  $E(x)$  is an odd function, (11) gives the necessary current distribution to produce the desired field distribution.

Equations (9) and (11) show an integration on  $\beta$  from zero to infinity. Since  $x$  or  $\beta$  lies between  $-1$  and  $1$  for real values of the angle  $\theta$ , we can say that for all values of  $x$  outside of this interval, the field shall be considered to be zero. This however is not a necessary restriction. It will be seen later that it may indeed be desirable to specify  $E(x)$  in this imaginary domain.

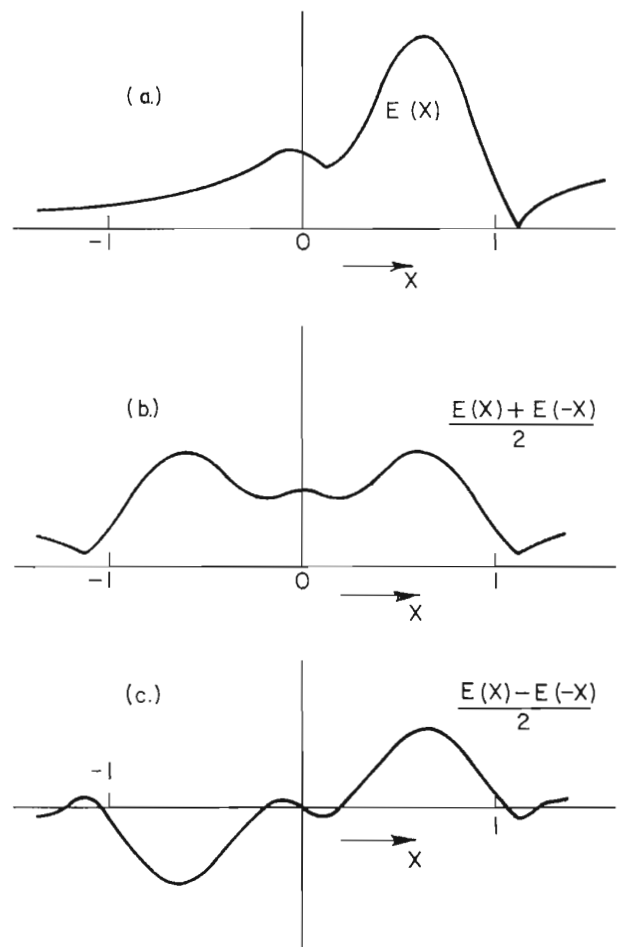

FIG. 2. A procedure for resolving an arbitrary field intensity distribution into an even function and an odd function.

If the desired field pattern is neither even or odd, (Fig. 2a), an even function to be used in equation (9) may be obtained by the method shown in Fig. 2b. Similarly, an odd function to be used in equation (11) may be obtained as shown in Fig. 2c.

### V. A Pattern with Constant Field Intensity within a Restricted Angle

As an example of the application of the foregoing equations, we shall examine the case where the desired field pattern is constant within a given angle and is zero at all other angles.

In this event:

$$E(\theta) = 1 \text{ when } -\theta_1 < \theta < \theta_1$$

$$E(\theta) = 0 \text{ when } \theta > \theta_1 \text{ or } \theta < -\theta_1$$

therefore

$$E(x) = E(\beta) = 1 \text{ when } -x_1 < x < x_1$$

and  $E(x)$  is zero for all other values of  $x$ , as shown in the upper right corner of Fig. 3. Since  $E(x)$  is an even function, equation (9) is appropriate to the problem and it becomes:

$$\frac{\lambda}{2} \text{Ki}(v) = \int_{\beta=0}^{\beta=x_1} \cos(v\beta) d\beta = \frac{\sin(vx_1)}{v} \quad (12)$$

$$\text{At } z = 0, \frac{\lambda}{2} \text{Ki}(0) = x_1$$

and

$$\frac{i(v)}{i(0)} = \frac{\sin(vx_1)}{vx_1} = \frac{\sin\left(\frac{2\pi z}{\lambda} \cdot x_1\right)}{\frac{2\pi z}{\lambda} \cdot x_1} \quad (13)$$

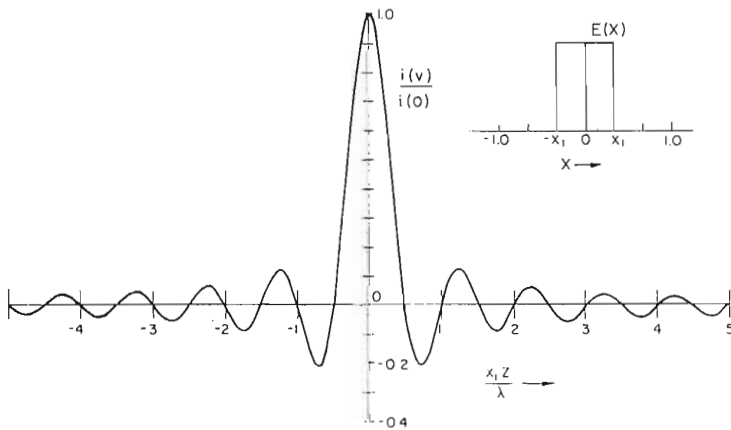

FIG. 3. Current distribution which will give a constant field intensity over a prescribed angular sector.

The relationship of equation (13) is shown in Fig. 3. It may be noted that as  $x_1$  becomes small, the current distribution spreads out along the array and a larger antenna is required.

In deriving equation (13), no constraint was placed on the value of  $x_1$ . If a constant field is desired for all values of  $\theta$  between  $-90^\circ$  and  $+90^\circ$ ,  $x_1$  may be chosen at any value greater than unity. Thus a variety of current distributions, however impractical they may be, will all give the same constant field pattern in the real region.

Because of the inter-relationships of Fourier Transforms, we could expect that a field intensity distribution of the shape of the current distribution shown in Fig. 3 would yield a new current distribution which was constant over an aperture and then became zero. For instance, if we desired a field intensity distribution where:

$$E(x) = \frac{\sin(Bx)}{Bx} \text{ for all values of } x, \text{ out to infinity,}$$

equation (9) would yield a current distribution such that:

$$i\left(\frac{2\pi z}{\lambda}\right) = 1 \text{ when } -B < \frac{2\pi z}{\lambda} < B$$

$$\text{and } i\left(\frac{2\pi z}{\lambda}\right) = 0 \text{ when } \frac{2\pi z}{\lambda} < -B \text{ or } \frac{2\pi z}{\lambda} > B$$

If, however, we desire this same field intensity distribution in the region of real angles ( $-1 < x < 1$ ) and assume that  $E(x)$  is zero for all values of  $x$  greater than unity or less than minus one, equation (9) becomes the sum of two sine-integral functions:

$$\frac{\lambda}{2} \text{Ki}(v) = \frac{1}{2B} \left[ \text{Si}(B+v) + \text{Si}(B-v) \right] \quad (14)$$

a solution which differs materially from the constant current over a finite aperture which results when the field pattern is considered to exist in both the real and imaginary regions.

## VI. Exponential Field Distribution

As another example, we shall examine the case of an even distribution of field where the field drops off on either side as:

$$E(\theta) = \epsilon^{-a \sin \theta}$$

or

$$E(x) = \epsilon^{-ax}$$

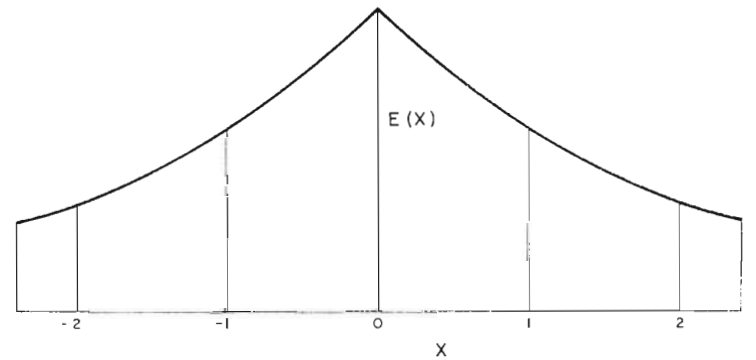

FIG. 4. An even function of field intensity distributed exponentially. ( $a = 0.5$ )

Figure 4 shows this field intensity distribution for a specific value of  $a$  equal to 0.5 and the field distribution extends to values of  $x$  greater than unity. At some value of  $x = x_1$  the field drops to zero and remains at zero for all values of  $x$  greater than  $x_1$ . Then equation (9) yields:

$$\frac{\lambda}{2} \text{Ki } v = \frac{a \left[ 1 - \epsilon^{-ax_1} \cos(vx_1) \right] + v \epsilon^{-ax_1} \sin(vx_1)}{a^2 + v^2} \quad (15)$$

Figure 5 shows three current distributions with  $a = 0.5$  and  $x_1 = 1$ ,  $x_1 = 2$ , and  $x_1 = \infty$ . Here are three separate current distributions all of which yield the same field intensity distribution in the real region. It is evident that the case where  $x_1$  is infinite yields the most conservative current distribution.

## VII. Tilted-Beam Pattern without Side Lobes

Equations (9) and (11) have been very useful in developing large antennas with narrow single beams and for lobe-switching antenna systems. This has been done by contriving even and

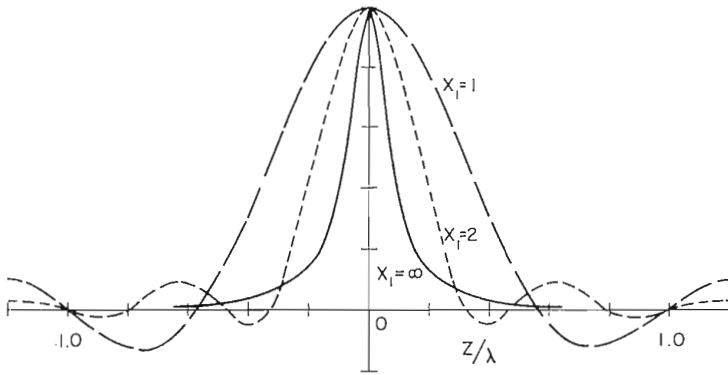

FIG. 5. Three current distributions which yield the field distribution of Fig. 4.

odd functions of field intensity which are readily integrable and which fit each other.

A useful even-function field distribution is:

$$E(x) = \cos^2\left(\frac{\pi x}{4x_1}\right) = \frac{1 + \cos\left(\frac{\pi x}{2x_1}\right)}{2} \quad (16)$$

from  $x = -2x_1$  to  $x = +2x_1$  with  $E(x)$  equal to zero for all other values. When  $x = x_1$ , the field intensity is one-half of the maximum value. A corresponding odd function is:

$$E(x) = \cos^2\left(\frac{\pi x}{4x_1}\right) \sin\left(\frac{\pi x}{4x_1}\right) \quad (17)$$

between  $x = -2x_1$  and  $x = 2x_1$  with  $E(x)$  equal to zero for all other values.

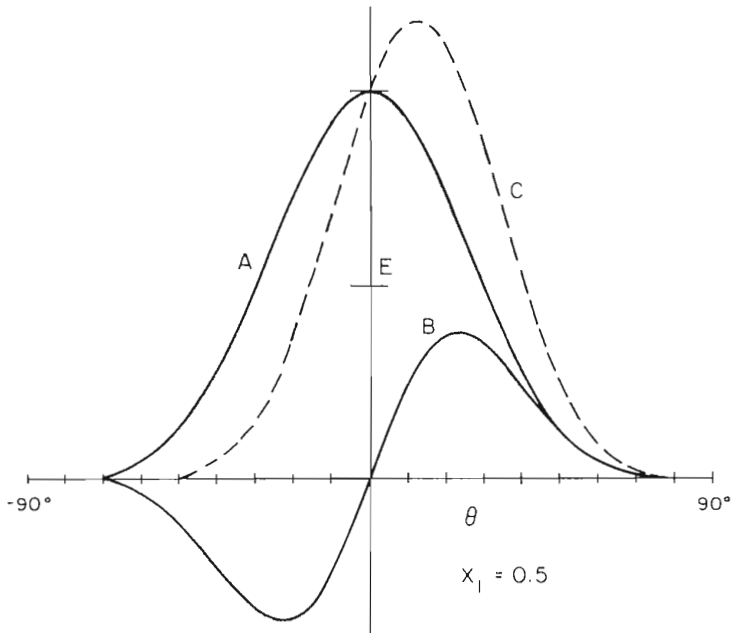

FIG. 6. A distribution of field useful in lobe-switching antenna systems, plotted as a function of  $\theta$ . Curve A is the even function of field, Curve B the odd function, while Curve C is the composite field. ( $x_1 = 0.5$ )

Curve A of Fig. 6 shows the even function of equation (16) plotted as a function of the angle,  $\theta$ , while Curve B shows the odd function of equation (17), where  $x_1 = 0.5$ . Curve C is the sum of the two field patterns. The same set of curves have been replotted as a function of  $x$  in Fig. 7.

Figures 8 and 9 show the corresponding family of curves where  $x_1 = 0.2$ . Successful lobe-switching antennas have been

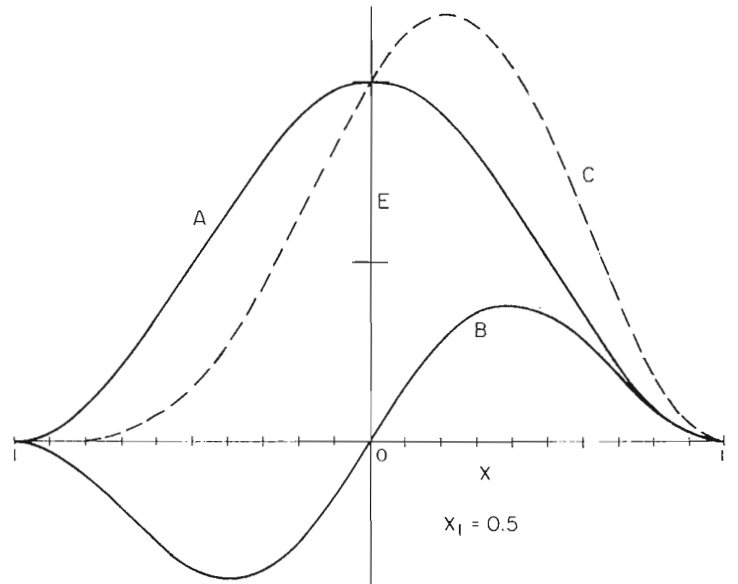

FIG. 7. The field distributions of Fig. 6 replotted as a function of  $x$ , ( $x = \sin \theta$ ).

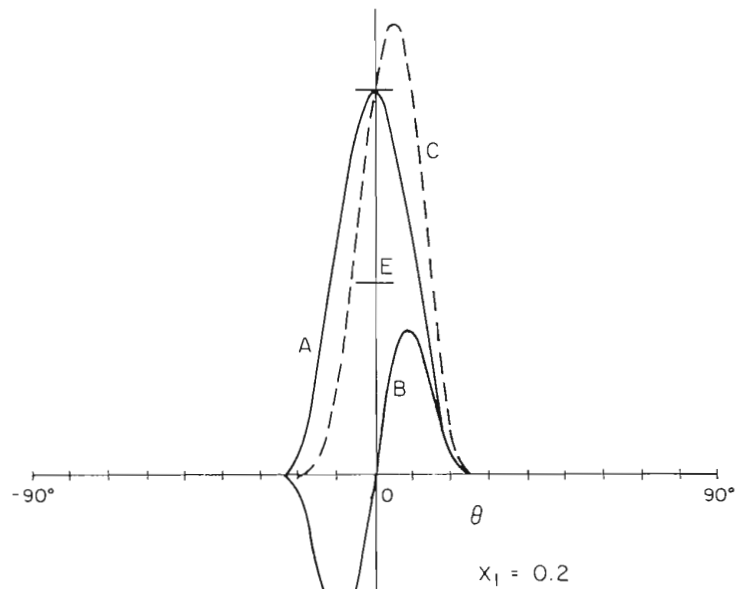

Fig. 8. Lobe-switching antenna patterns similar to Fig. 6. ( $x_1 = 0.2$ )

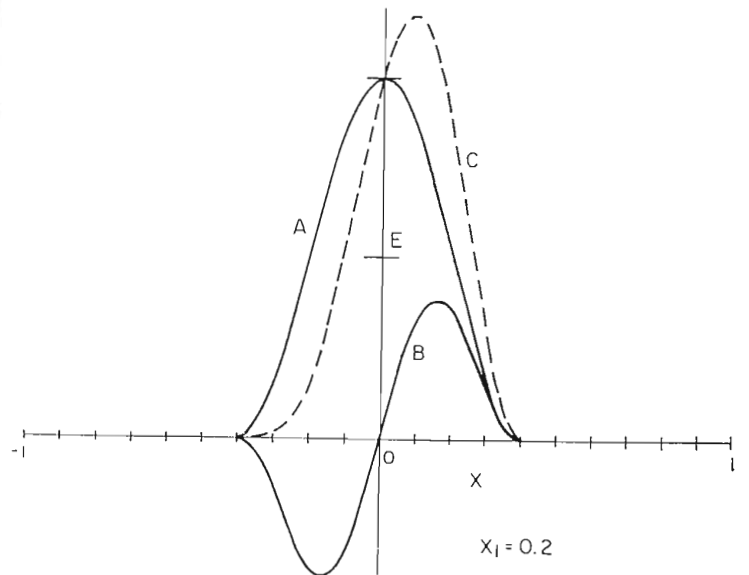

FIG. 9. A replot of Fig. 8 as a function of  $x$ .

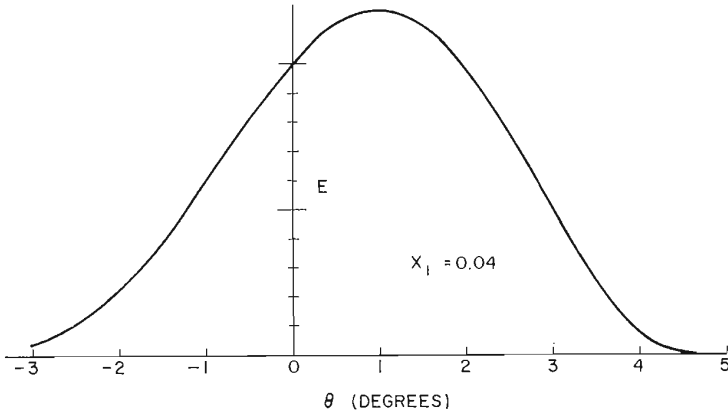

FIG. 10. A very narrow tilted beam. ( $x_1 = 0.04$ )

designed where the current distribution yielding Curve B has been rapidly reversed in phase.

Figure 10 shows the total field distribution for a very narrow beam, where  $x_1 = 0.04$ .

When equation (16) is substituted into equation (9) we find:

$$\frac{\lambda}{2} \text{Ki}(v) = \int_{\beta=0}^{\beta=2x_1} \cos^2\left(\frac{\pi}{4} \frac{\beta}{x_1}\right) \cos(v\beta) d\beta = \quad (18)$$

$$\frac{\sin\left(\frac{4\pi z}{\lambda} x_1\right)}{\frac{4\pi z}{\lambda}} \left[ \frac{1}{1 - \left(\frac{4z x_1}{\lambda}\right)^2} \right]$$

At the center of the array,  $z = 0$ , the current density is:

$$\frac{\lambda}{2} \text{Ki}(0) = x_1 \quad (19)$$

so the current density distribution is obtained by dividing (19) into (18).

$$\frac{i(v)}{i(0)} = \frac{\sin\left(\frac{4\pi z x_1}{\lambda}\right)}{\frac{4\pi z x_1}{\lambda}} \left[ \frac{1}{1 - \left(\frac{4z x_1}{\lambda}\right)^2} \right] \quad (20)$$

This function is plotted in Fig. 11 as  $i_s$  and is equally applicable to the field distribution of Fig. 7 or Fig. 9.

When the odd function of equation (17) is substituted into equation (11),

$$j \frac{\lambda}{2} \text{Ki}(v) = \frac{x_1}{2\pi} \left(\frac{4z x_1}{\lambda}\right) \cos \frac{4\pi z x_1}{\lambda} \left[ \frac{1}{\left(\frac{1}{2}\right)^2 - \left(\frac{4z x_1}{\lambda}\right)^2} \right. \quad (21)$$

$$\left. - \frac{1}{\left(\frac{3}{2}\right)^2 - \left(\frac{4z x_1}{\lambda}\right)^2} \right]$$

To normalize this odd function of current density, we divide (21) by the current density of the even function at  $z = 0$  and obtain

$$j \frac{i(v)}{i(0)_s} = \frac{1}{2\pi} \left(\frac{4z x_1}{\lambda}\right) \cos\left(\frac{4\pi z x_1}{\lambda}\right) \left[ \frac{1}{\left(\frac{1}{2}\right)^2 - \left(\frac{4z x_1}{\lambda}\right)^2} \right. \quad (22)$$

$$\left. - \frac{1}{\left(\frac{3}{2}\right)^2 - \left(\frac{4z x_1}{\lambda}\right)^2} \right]$$

The odd-function current density distribution of (22) is plotted as the unsymmetrical distribution labeled  $i_u$  in Fig. 11.

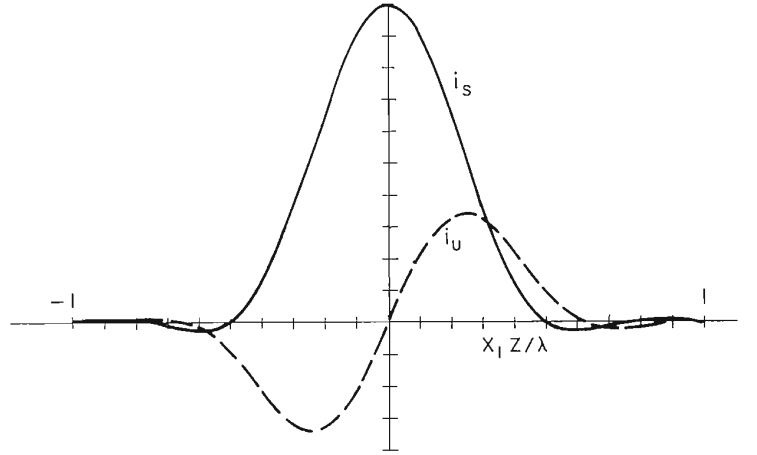

FIG. 11. The odd and even functions of current distributions to obtain the field intensities of Figs. 6 to 10.

It should be noted that the current distribution of (22) lags that of (18) by  $90^\circ$ . Then the total current distribution and the corresponding phase angle to obtain the pattern C of Figs. 7 and 9 are given in Fig. 12.

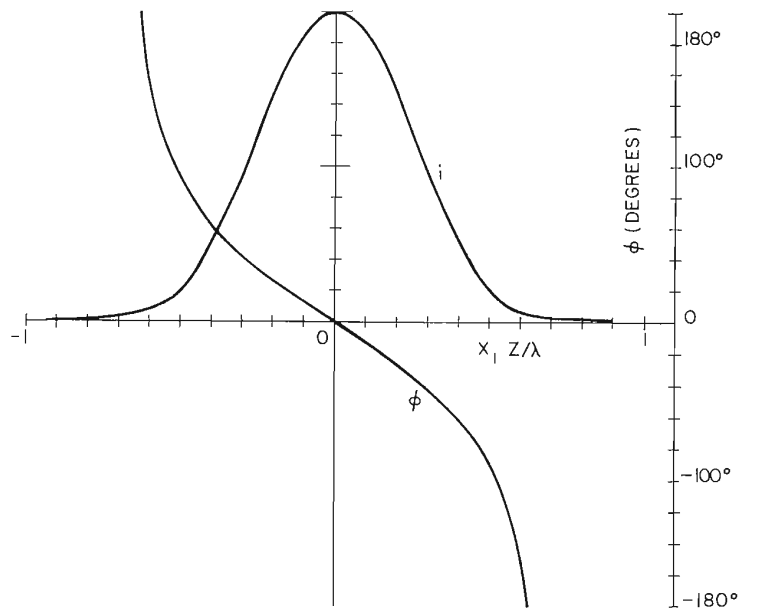

FIG. 12. The current distribution of Fig. 11, shown in terms of total current magnitude and phase angle.



### VIII. Beam-Tilted Cosecant-Theta Pattern

A tilted beam with a cosecant distribution over most of the positive real angle has been of some interest. The total field distribution is shown in Fig. 13a.

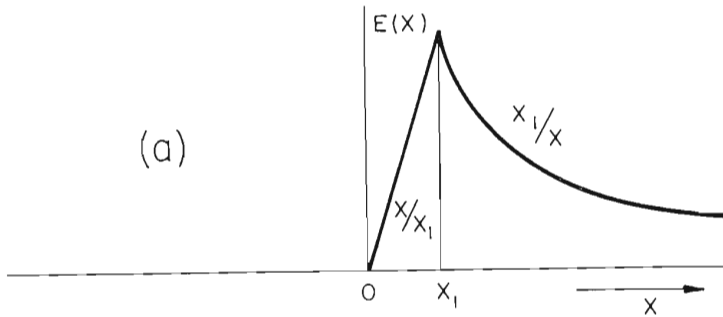

FIG. 13a. A cosecant field distribution.

$$E(x) = 0 \text{ when } x < 0$$

$$E(x) = x/x_1 \text{ when } 0 < x < x_1$$

$$E(x) = x_1/x \text{ when } x_1 < x < 1$$

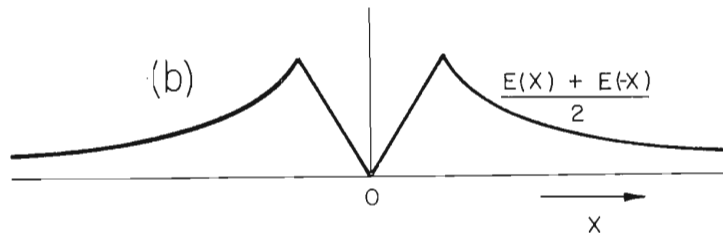

FIG. 13b. The even-function component.

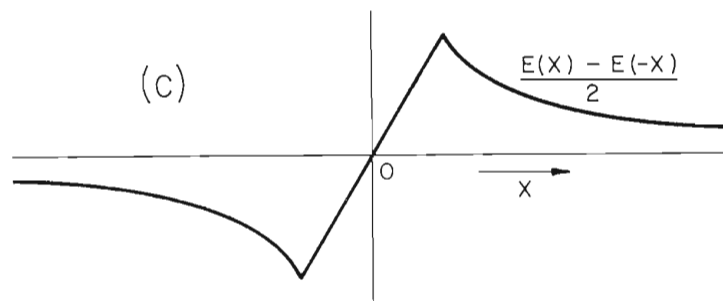

FIG. 13c. The odd-function component.

To find the even and odd distributions to use in the Fourier integrals, we follow the procedure demonstrated in Fig. 2. Then for the even function, shown in Fig. 13b, we obtain:

$$E(x) = \frac{x}{2x_1} \text{ when } 0 < x < x_1$$

$$E(x) = \frac{x_1}{2x} \text{ when } x_1 < x < 1$$

and the even-function distribution of current density is:

$$\frac{\lambda}{2} \text{Ki}(v) = -\frac{1}{2x_1} \int_{\beta=0}^{\beta=x_1} \beta \cos(v\beta) d\beta + \frac{x_1}{2} \int_{\beta=x_1}^{\beta=1} \frac{\cos(v\beta)}{\beta} d\beta + \frac{x_1}{2} \left[ \frac{(vx_1) \sin(vx_1) + \cos(vx_1) - 1}{(vx_1)^2} + \text{Ci}(v) - \text{Ci}(vx_1) \right] \quad (23)$$

The odd-function distribution of field is

$$E(x) = \frac{x}{2x_1} \text{ when } 0 < x < x_1$$

$$E(x) = \frac{x_1}{2x} \text{ when } x_1 < x < 1$$

while the odd-function distribution of current density is

$$j \frac{\lambda}{2} \text{Ki}(v) = \frac{1}{2x_1} \int_{\beta=0}^{\beta=x_1} \beta \sin(v\beta) d\beta + \frac{x_1}{2} \int_{\beta=x_1}^{\beta=1} \frac{\sin(v\beta)}{\beta} d\beta + \frac{x_1}{2} \left[ \frac{\sin(vx_1) - (vx_1) \cos(vx_1)}{(vx_1)^2} + \text{Si}(v) - \text{Si}(vx_1) \right] \quad (24)$$

### IX. Conclusion

Mathematical methods of determining the magnitude and phase of the current distribution over an extended linear antenna aperture in order to obtain a desired directive pattern have been described. It has been shown that the radiation pattern and the current distribution form a set of Fourier Transforms, thus yielding a ready solution to the problem. By adding a pattern in an imaginary zone to the real pattern, many current distributions or array configurations are found, all of which give the same desired pattern in the real zone.

# LATEST TRENDS IN TV BROADCAST ANTENNAS

*Simplified Construction Makes Slotted-Cylinder Antennas Extremely Reliable While Producing Smooth Patterns to Meet Specific Requirements*

by H. E. GIHRING, Manager Antenna Engineering

Improvements in television broadcast antennas resulting from 15 years of extensive design experience have produced new types of antennas combining the functions of both a mast and a radiator. Feed systems have been simplified by using a single conductor inside a slotted cylinder. Smooth vertical patterns and a large variety of horizontal patterns to meet various situations can be produced by the inherent flexibility of a slotted cylinder antenna. Improved measuring techniques have helped produce these radiator—mast antennas that will meet the highest standards of modern TV broadcasting.

## The Slotted-Cylinder Antenna

When it is considered that the function of an antenna is to convert the power

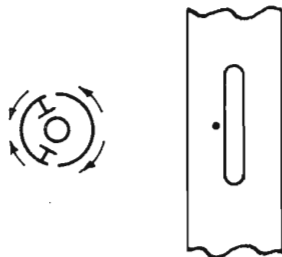

FIG. 1. Capacity coupled energy from a single continuous inner conductor to the radiating slotted cylinder, which is also the outer conductor of the single transmission line feed system. The slots are used in pairs and fed in opposite phase to provide radiation similar to that of a dipole.

flowing in a transmission line into radiated power, the ultimate solution is to cut holes in the transmission line to let the power leak out in the desired manner. By arranging the holes or slots in a proper fashion considerable flexibility is obtained. For instance, the height of the slotted portion determines the gain of the antenna. The relative amount of energy fed to each section of the antenna, and the phase determine the shape of the vertical pattern. The number of slots in each section (or layer), their disposition, and method of feed determine the horizontal pattern.

A smooth, galvanized, heavy-wall, piece of steel tubing is the ultimate in simplicity and reliability. It combines the functions of mast and radiator. It provides the minimum wind load attainable.

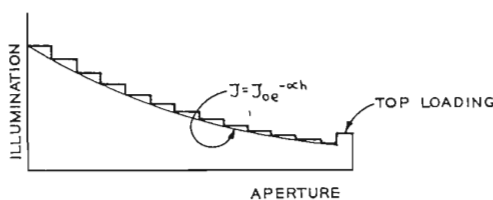

FIG. 2. Magnitude of illumination of the Traveling Wave Antenna. Uniform coupling along the aperture produces the exponentially decaying portion, which results in a vertical pattern substantially free from nulls.

## Simplified Feed Systems

For typical omnidirectional antennas the power gain has a value from 0.7 to 1.0 per wavelength of height. When relatively few layers were used during the forties and early fifties to attain the effective radiated power (ERP) required, the simplest method of distributing the power to each radiating element was by means of separate feed lines. As the value of ERP was increased, antenna gain was also increased. This resulted in a great number of feed lines and junction boxes in the distribution system which added complexity.

Feed systems can be greatly simplified in slotted cylinder antennas by using capacity probes at each slot to extract power from a continuous inner conductor. Various methods are used to accomplish this.

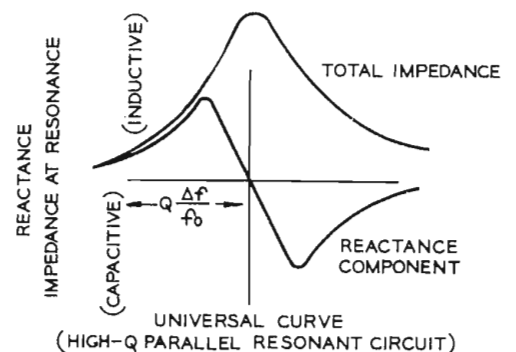

FIG. 4. The reactance of the slot off-resonance provides the required compensation to obtain substantially uniform phase across the channel.

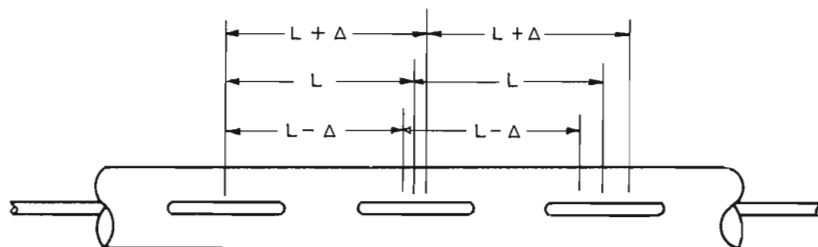

FIG. 3. The center-to-center slot spacing "L" is determined by the mid-band frequency of the channel. Frequencies at the high and low end of the channel have a progressive phase error of  $\Delta$  per slot unless compensation means are used.

## TWA Feed System

In the RCA Traveling Wave Antenna<sup>1,2</sup> the probes are arranged as shown in Fig. 1. Each layer extracts a certain percentage

<sup>1</sup> M. S. Siukola and G. A. Kumpf, "Traveling Wave Antenna," *Broadcast News*, Vol. No. 94, April, 1957.

<sup>2</sup> G. E. Erwin, "Traveling Wave Antenna Proves Itself in Service," *Broadcast News*, Vol. No. 103, March, 1959.

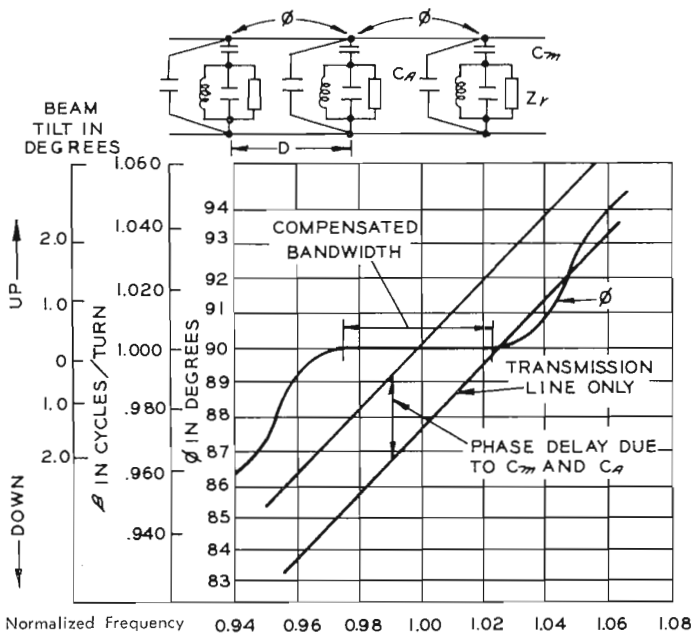

FIG. 5. Compensated phase response across the television channel.

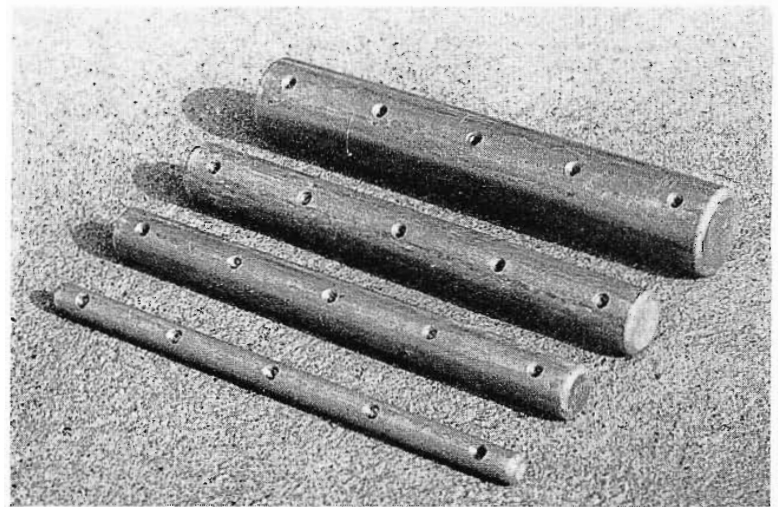

FIG. 6. This type of metal cylindrical coupler is used in UHF antennas. Its design permits adjustment of both phase and amplitude of the radiated field. Cylindrical coupling is mechanically simple, yet capable of handling high power.

of the energy at a chosen rate (see Fig. 2) so that the desired vertical pattern is achieved.

In using such a feed system for a number of layers, the center-to-center slot spacing "L" in Fig. 3 is nominally correct for the center of the channel. For the upper and lower edges of the channel the center-to-center spacing is not correct unless some compensation is provided. In the Traveling Wave antenna this is accomplished by the reactance of the slot off-resonance (see Fig. 4), which increases the capacitive reactance at the high frequency end and reduces it at the low frequency end so that the number of wavelengths in the aperture is substantially the same across the channel. Without such compensation the vertical pattern maximum would tilt upwards at the high frequency end and downwards at the low frequency end, resulting in a form of amplitude distortion. With the compensation as used, however, excellent characteristics are achieved<sup>3</sup> as shown in Fig. 5.

#### UHF Feed Systems

The ultra-gain antenna has a nominal gain of 50 in the UHF band. It formerly used inductive loop coupling. This was superseded by a unique type of probe coupling which uses cylindrical pieces of metal (see Fig. 6) fastened along the inside edge of the slot (see Fig. 7) which couple to the inner conductor.

This method provides a high degree of

flexibility, permitting both the phase and amplitude of the radiated field to be varied to produce a wide variety of patterns. Compensation across the channel is inherent with this method when the proper degree of coupling is used. This all-metal coupling is mechanically simple and rugged, capable of handling high power, and makes achieving the necessary bandwidth possible because a desirable loading can be chosen independent of illumination.

#### Higher Gain Antennas

Early antennas had power gains (referred to a dipole) from three to six. It soon became apparent that increasing gain was an economical method of achieving a higher value of effective radiated power which, when properly directed, increased

coverage. Cost analyses have indicated that in many cases effective radiated power achieved by means of antenna gain is more economical than increasing the transmitter power. This relationship holds as long as the antenna length does not exceed 175 to 200 feet—at which point the structural costs become proportionately higher due to the large unsupported height. If the antenna is guyed, this limitation does not hold. A number of antennas with gains up to 50 have been built for UHF and have had no limitation in coverage caused by bending in high winds. It should be pointed out, however, that these antennas were designed not to have deep valleys in the vertical pattern so that bending of the antenna due to wind did not periodically result in excessive field strength variations.

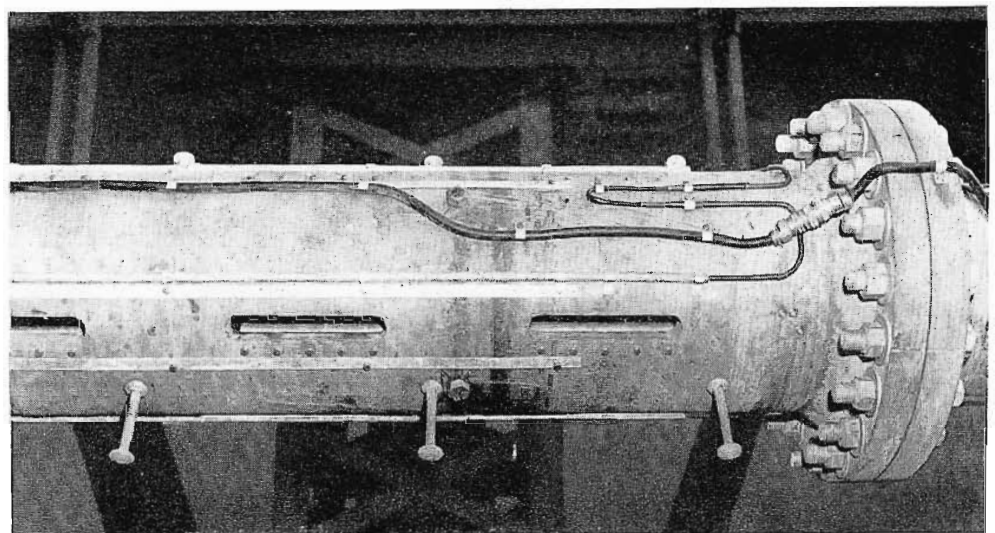
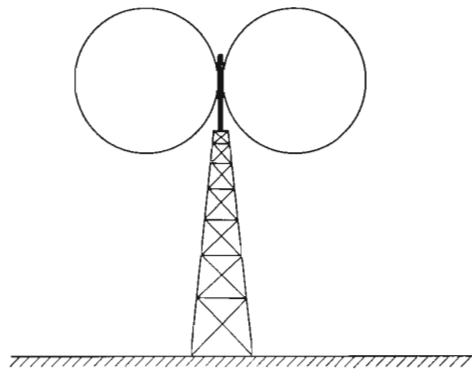

FIG. 7. Cylindrical couplers are mounted in the inside edge of the slot.

<sup>3</sup> M. S. Siukola, "Traveling Wave Television Broadcast Antenna," *AIEE Conference Paper* No. 59-459, Winter General Meeting, New York, Feb., 1959.



VERTICAL PATTERN  
SINGLE BAY OMNIDIRECTIONAL  
ANTENNA  
POWER GAIN -1

A

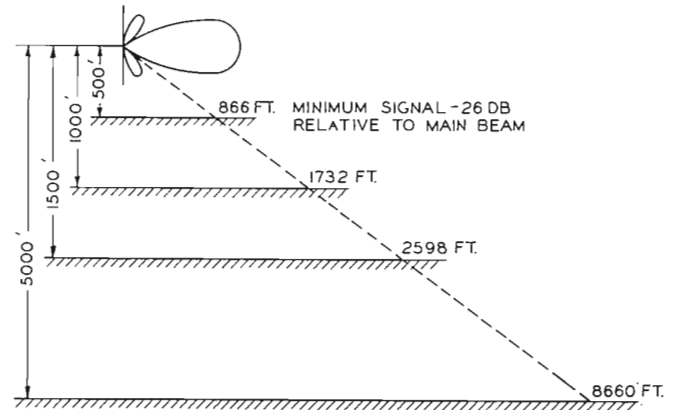

MINIMUM SIGNAL LOCATIONS  
STACKED OMNIDIRECTIONAL ANTENNA  
POWER GAIN 2.4

B

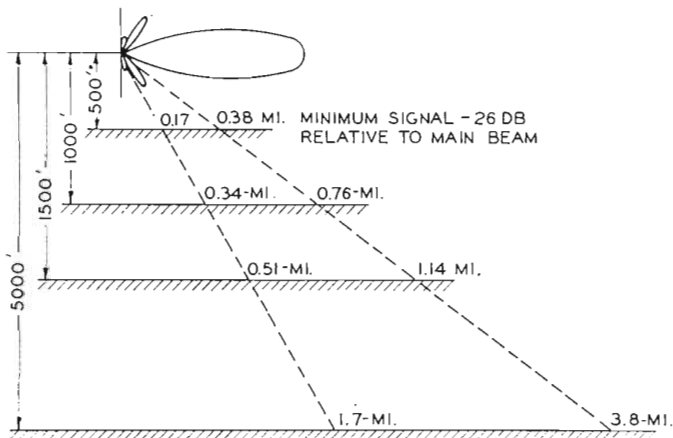

MINIMUM SIGNAL LOCATIONS  
STACKED OMNIDIRECTIONAL ANTENNA  
POWER GAIN 5.0

C

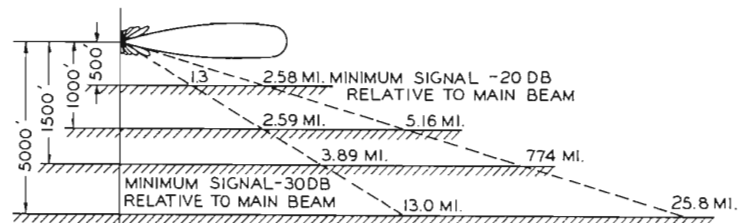

MINIMUM SIGNAL LOCATIONS  
UHF ANTENNA TYPE TFU-24-BH  
18-BAY CHANNEL 76 84.4 MC

D

FIG. 8A, B, C, D. As antenna gain is increased, nulls appear at increasing distances from the antenna. Null-fill or elimination is essential in higher gain antennas.

### Nulls

Television broadcast antennas usually consist of a number of radiators such as dipoles, batwings, slots, etc., stacked above each other. As soon as more than one radiator is used with a spacing more than a half wavelength apart nulls begin to appear in the vertical pattern as can be seen in Fig. 8b. As the gain is increased more nulls appear (see Figs. 8c, 8d). Hence, depending on the gain and the elevation above terrain many nulls may be located in the service area at the distances shown.<sup>4</sup>

<sup>4</sup> An approximate rule for determining the location of the farthest null from the antenna is: multiply the height of the active portion of the antenna in wave lengths (aperture) by the height above terrain in feet by the constant 0.00019.

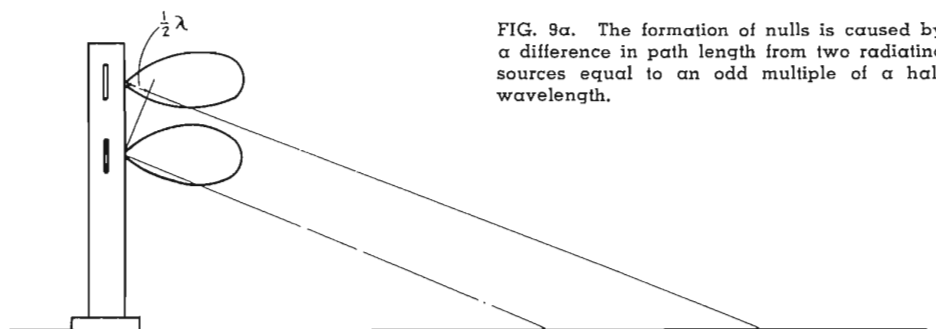

FIG. 9a. The formation of nulls is caused by a difference in path length from two radiating sources equal to an odd multiple of a half wavelength.

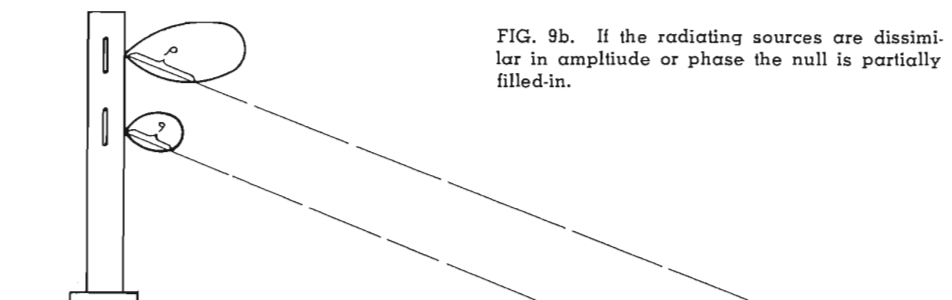

FIG. 9b. If the radiating sources are dissimilar in amplitude or phase the null is partially filled-in.

Usually nulls within the first mile or so of the antenna present no problem since the energy level is so high that even a few percent of fill due to mechanical dissymmetries (which are always present) will provide an adequate signal. Beyond this point something more positive must be done.

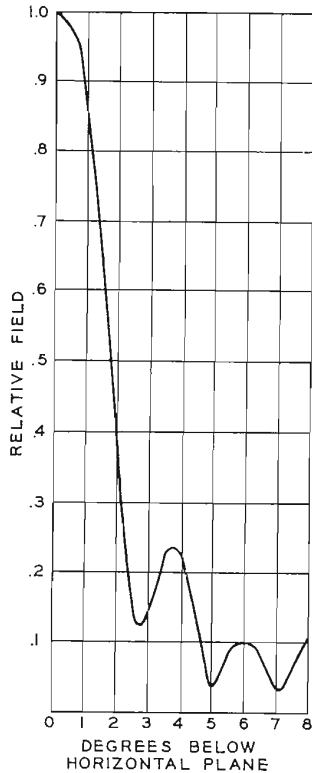

FIG. 10. A typical "null-filled" pattern is obtained by varying the amplitude and phase between the upper and lower portions of the antenna.

#### Null Fill

When two or more like radiators having the same power input and phase relationship are stacked above each other, a null appears when the difference in path length from each radiator to a given point<sup>5</sup> on the ground is one-half wavelength or an odd multiple of this value (see Fig. 9a). One obvious way to avoid such nulls is to supply different amounts of power to various sections of the antenna or to each radiator or to change their phase relationship. Although the path difference in Fig. 9b is still one-half wavelength the values of  $p$  and  $q$  are different due to the difference in power level and complete cancellation does not occur. Such an arrangement is known as "null fill." The peaks and valleys in the vertical pattern are still discernible but the minimum points do not go to zero. Figure 10 is a typical "null filled" pattern.

<sup>5</sup> Far enough away so that the rays are substantially parallel.

FIG. 11. This shows how large variations in a null-filled pattern could cause severe "ghosting" under certain conditions when the reflected signal from a peak is of the same order as the direct signal from a valley in the pattern.

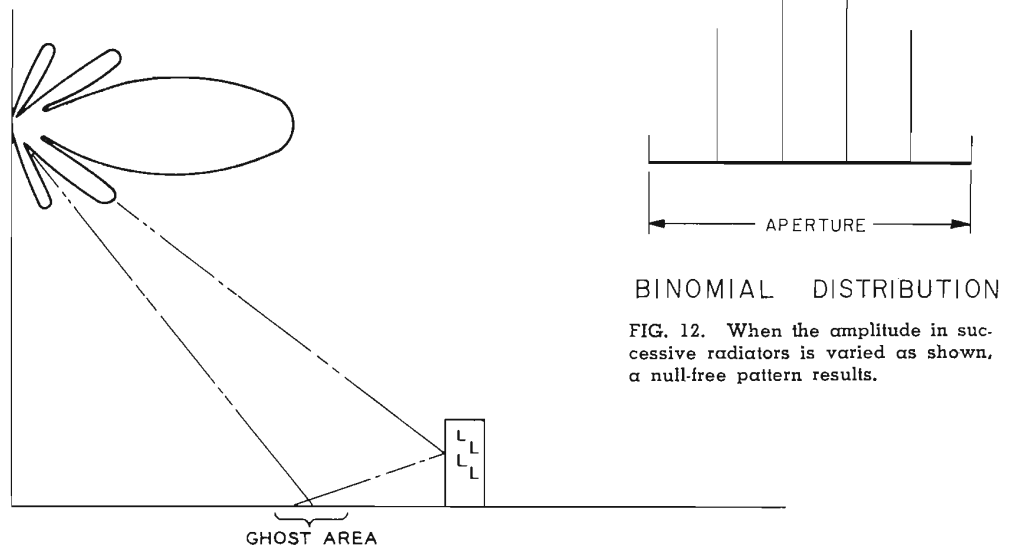

FIG. 12. When the amplitude in successive radiators is varied as shown, a null-free pattern results.

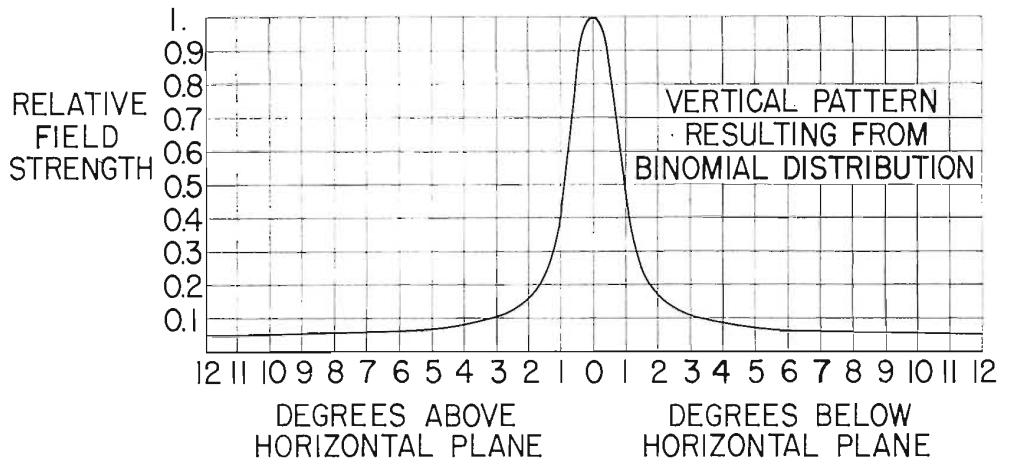

FIG. 13. A null-free pattern resulting from binomial distribution.

#### Smooth Vertical Patterns

There are a number of advantages in eliminating nulls and providing a relatively smooth vertical pattern. For instance in Fig. 11, a condition is depicted where a null filled pattern could result in a higher degree of ghosting in certain areas as compared to a smooth pattern.

Smooth vertical patterns can be obtained if the energy to each radiator is varied in a certain prescribed manner. When a binomial distribution<sup>6</sup> is used as shown in Fig. 12 a vertical pattern free from nulls will result as shown in Fig. 13. A null free pattern is also obtained by an exponential distribution such as shown in Fig. 2. This distribution is inherent for the Traveling Wave Antenna and produces a pattern that is substantially null free (see Fig. 14).

#### Beam Tilt

Because of the curvature of the earth an antenna 1000 feet above terrain must be aimed 0.48 degrees below the horizontal to aim at the horizon. With an antenna having a wide beam<sup>7</sup> this factor is insignificant. For an antenna with a gain of 50, however, with a beam width of about 1.2 degrees, the ability to tilt the beam downward in all directions is highly important.

Beam tilt can be obtained within limits by, advancing the phase of the upper

<sup>6</sup> J. D. Kraus, "Antennas" (McGraw-Hill Co., New York, 1950), Sec. 4-7, Page 94.

<sup>7</sup> The beam width between half-power points (0.707 voltage points) is approximately  $61/G$  degrees, when  $G$  is the gain of the antenna. This formula is correct only if the aperture efficiency factor approaches a gain of 1.22 per wave length of height.

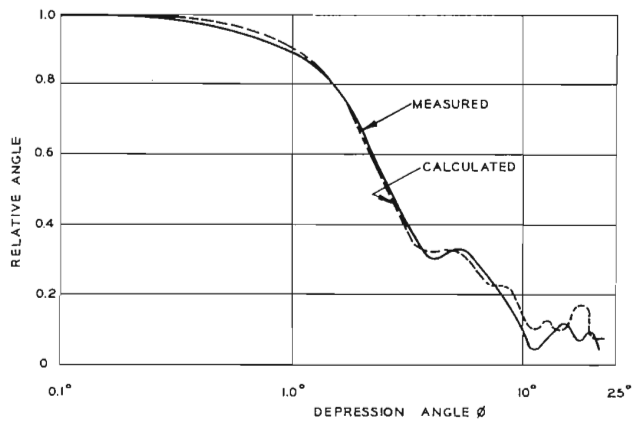

FIG. 14. Pattern resulting from exponential distribution as shown in Fig. 2. Note close correlation between calculated and measured pattern.

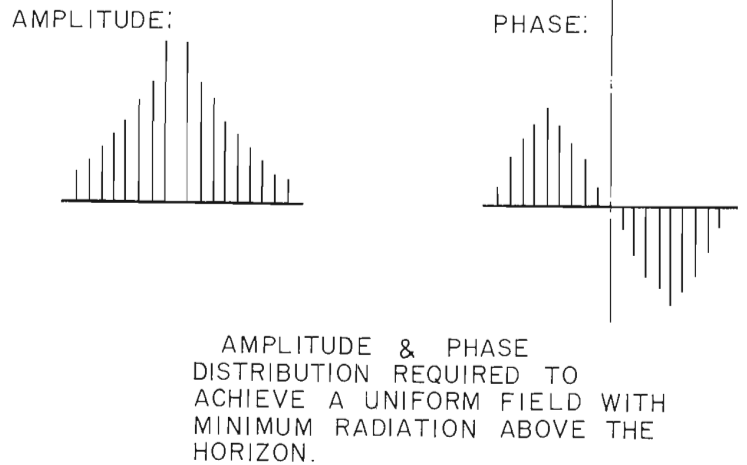

FIG. 15. By proper choice of amplitude and phase for each radiator, a vertical pattern can be obtained that is null-free, provides the required beam tilt, and minimizes radiation above the horizon to improve aperture efficiency.

portion of the antenna and retarding the lower portion although some pattern distortion may result. If the phase is linearly changed for each radiator it has the same effect as moving the entire vertical pattern to the right with respect to the degree scale (as shown in Fig. 13). There is little distortion of the pattern if the movement is limited to several degrees.

#### Reducing Radiation above the Horizon

In the pattern shown on Fig. 13 as much energy is radiated above the horizon as below. Beam tilting places more of the radiated energy below the horizontal. However, by properly choosing the phase of each radiating element, energy above the horizontal can be cancelled to a great extent thus increasing the aperture efficiency factor (gain for a given height).

#### Pattern Synthesis

The objectives discussed above, namely: (1) The elimination of nulls, (2) Beam tilt by linear phase change, and (3) Reducing energy above the horizontal, can be accomplished by synthesizing the desired pattern.<sup>8</sup> The vertical pattern depends entirely on the current amplitude and phase of each radiating element. By using an amplitude and phase distribution such as shown in Fig. 15 a pattern as shown in Fig. 16 can be achieved. The method is quite flexible and a great variety of patterns for various needs can be achieved. The use of slotted cylinders permits a high degree of flexibility in con-

trolling the amplitude and also the phase of the radiators.

#### Synthesized Vertical Patterns for Specific Applications

With techniques currently available it is possible to provide patterns for special situations. For instance, station WXYZ (channel 7) Detroit, Michigan required a special null to keep the field strength at a specified point in one direction below a certain value. Such a null was built into the pattern which covered an azimuth of 32 degrees in the horizontal pattern and had a magnitude of 2.5 per cent in the vertical pattern from 13.5 to 18 degrees below the horizontal.

In some cases it is desired to replace a UHF antenna with a nominal gain of 24 by a higher-gain antenna, but still maintain

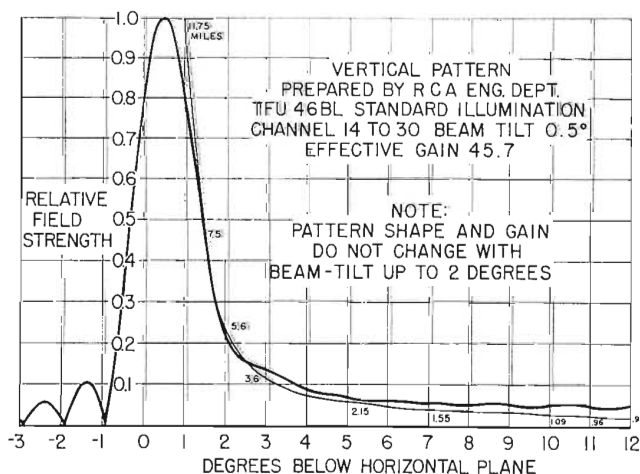

FIG. 16. Patterns obtained as a result of the amplitude and phase distribution shown in Fig. 15.

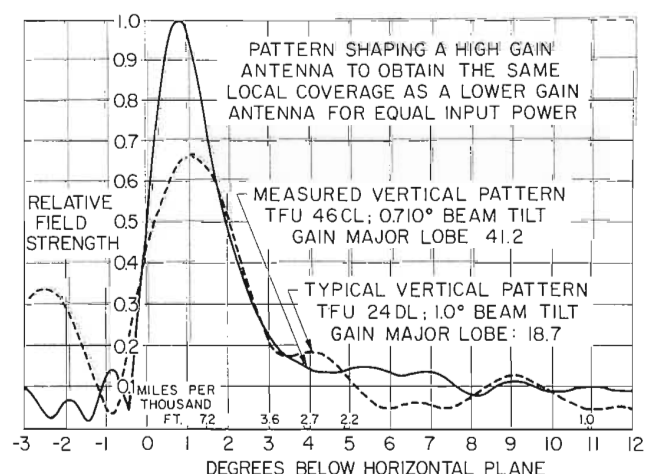

FIG. 17. A higher-gain antenna can provide local coverage equivalent to that of a lower-gain antenna under the conditions as shown.

the same local coverage with a pattern that normally has much less beam width. Figure 17 shows the patterns of both the low gain and the high gain antenna. It can be seen that the local coverage is maintained and even improved although the gain is increased 2.2 times.

### Horizontal Pattern Flexibility

Slotted cylinders provide a high degree of flexibility by providing horizontal patterns of all types, from omnidirectional to a large variety of directional patterns. Most antennas in use today have omnidirectional patterns transmitting in all directions. Several principles have been used to achieve omnidirectional horizontal patterns.

One of these is the turnstile principle in which two figure eight patterns, as produced by two dipoles (Fig. 1) are added in quadrature thus producing a circular pattern. The four slots in two adjacent layers of a Traveling Wave Antenna<sup>8</sup> can be thought of as two crossed dipoles fed in quadrature which produce an omnidirectional pattern.

An omnidirectional pattern can also be achieved by the use of a horizontal loop of sufficiently small diameter. A cylinder with a single slot can be thought of as a number of loops stacked above each other. When the diameter over wavelength ratio is 0.14 a circularity of  $\pm 1.6$  db can be achieved as shown in Fig. 18.

By changing the diameter over wavelength ratio and varying the number of slots a large number of patterns, both directional and omnidirectional, can be achieved. A few of these are shown in Fig. 18. Almost any reasonable pattern can be provided by varying the available parameters.

The horizontal patterns achieved by slotted cylinders are very stable both electrically and mechanically. This is a mandatory requirement, for a directional antenna when it is used, for reducing mileage separation.

### Importance of Reliability

Because of its relative inaccessibility, reliability is one of the most important qualities of an antenna. During periods of high wind or ice it is completely inaccessible, and during other periods work can usually be performed only by riggers—who, incidentally are not generally skilled in the use of electrical measuring devices. Reliability can be broadly defined as the ability of the antenna to meet its electrical and mechanical specifications without deterioration throughout its life.

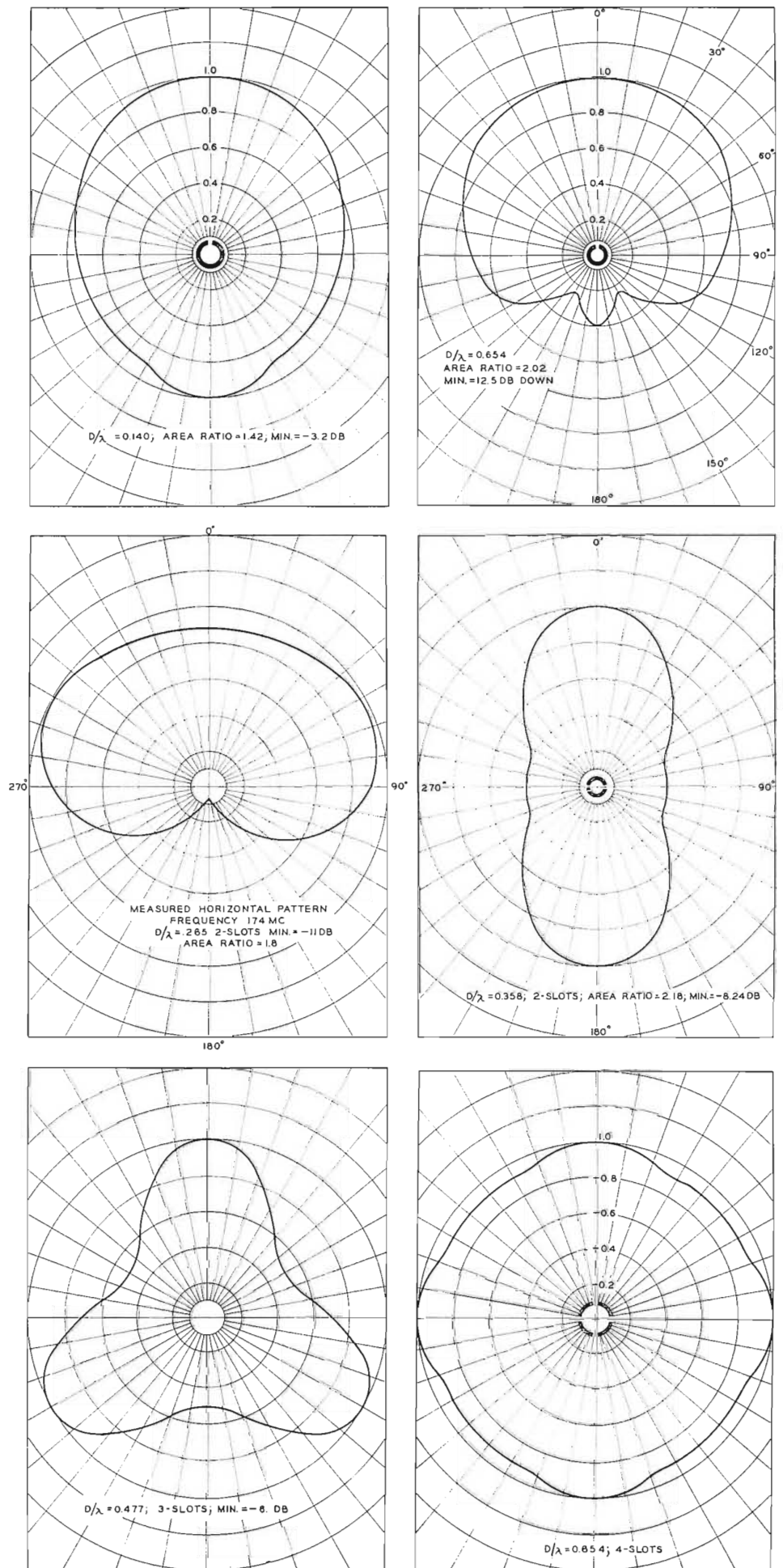

FIG. 18. Typical horizontal patterns that demonstrate the versatility of slotted cylinders. By varying the number of slots, method of feed, and diameter to wavelength ratio, almost any reasonable pattern can be obtained.

## Weather Resistant Antennas

An antenna is subject to fairly severe environmental conditions. It is a frequent target for lightning. Icing and wind conditions are usually more severe than at ground level. Near the ocean, salt atmosphere hastens corrosion. Using the background obtained from over 600 TV broadcast antennas, RCA engineers have designed a highly reliable antenna.

A slotted-cylinder is practically immune to damage by lightning. It also presents the minimum possible wind load, since it is almost a perfect round. Deicing with strip heaters is quite simple and reliable. Since a slotted cylinder antenna combines the functions of mast and radiator, there is no ice formation on either.

In types of antennas where only the radiators are deiced, the formation of ice is possible on the balance of the antenna—which can be detrimental under severe conditions.

Damage due to handling and climbing of the slotted cylinder is negligible since there are no exposed vital parts. Hot-dipped galvanized steel, used in all of the slotted cylinder antennas, has proven to be excellent in salt atmosphere. Other materials used such as copper, treated aluminum, stainless steel and teflon are equally durable.

A small open section of the Traveling Wave Antenna consisting of the outer cylinder, inner conductor and probes was mounted on a tower on Mt. Sutro in San Francisco for a period of a year and found to be in perfect condition after that time. This location with heavy salt-laden fog rolling in frequently from the Pacific provides as severe a test condition as can be found in this country.

The inner conductor consists of copper tubing. Probes are aluminum turnings, or rods, which couple energy from the inner conductor. The large inner conductor and the probes constitute the entire distribution system. This results in an antenna with a minimum number of parts, made of excellent materials, and of very conservative power rating.

Antennas are installed under the supervision of RCA Service Company engineers who are specially trained for this type of work. All of these factors result in reliable, trouble-free performance.

## Better Measuring Techniques

An antenna radiates electro-magnetic energy, which is not the easiest quantity to measure—especially when both vertical and horizontal patterns must meet fairly

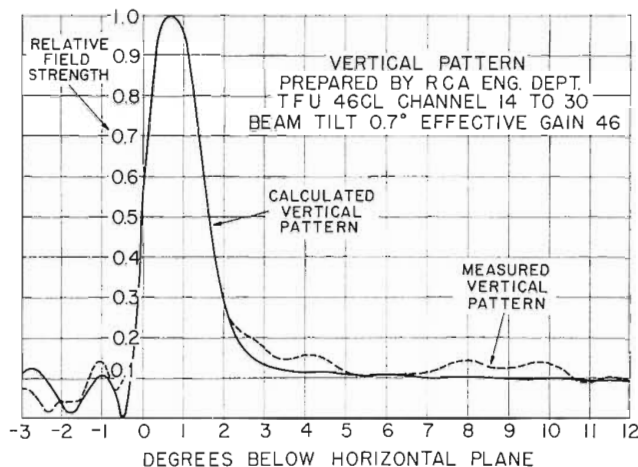

FIG. 19. Correlation between a measured and calculated vertical pattern of a high-gain UHF antenna with a uniform 10 percent fill. This comparison of measured vs. calculated pattern is easily obtained at RCA's extensive antenna test facilities where every new antenna type is tested in this manner. Horizontal patterns are also compared during the tests.

rigid requirements. Such measurements would be simplified if they could be made out in space, since the largest source of error is reflection from the earth and other objects. By using good sites and proper techniques these difficulties can be minimized. The RCA Test Facilities<sup>9</sup> for measuring TV antenna performance were carefully chosen to avoid reflections. The full-size antenna is rotated on a single pivot turntable capable of withstanding the load. Antennas 130 feet long and weighing up to 14 tons have been pattern tested using these facilities.

Patterns are continuously recorded. Linearity of the system is checked by high quality attenuators. Figure 19 shows a calculated and measured pattern using these facilities. Patterns are taken on all prototypes and on most custom antennas.

## Gain Measurements

The gain of the antenna is calculated from eight to twelve vertical patterns taken in various directions and an azimuthal pattern taken at the peak of the vertical pattern. On prototypes a pattern of the vertically polarized energy is also taken, which is used to correct the gain figure. This energy can be appreciable on some types of antennas and may reduce the gain considerably. It is not proper to include vertically polarized energy as radiated power since the standards are based on horizontal polarization.

## Aperture Efficiency Factor

An ideal omnidirectional antenna having no cross polarization, and no losses, with

a uniform current and phase distribution (which produces zero nulls) will have a power gain, referred to a dipole, of 1.22 times the aperture of the antenna in wavelengths.<sup>10</sup> The aperture of an antenna is the active radiating portion. It is defined as the dimension from the lowest point of the bottom radiator to the highest point of the top radiator.<sup>11</sup> Since most antennas have some vertical polarization and some losses, a value of 1.22 is never achieved in practical TV antennas—when all the factors are taken into account. The actual gain per wavelength of aperture is defined as the aperture efficiency factor.

In the Superturnstile Antenna the feed system contributes an average loss of about 6 percent, cross-polarized component about 7 percent, and a 3 percent safety factor is used to allow for manufacturing tolerances.

A very important item influencing the aperture efficiency factor is the amount of "fill" in the vertical pattern. The gain figure of 1.22 per wavelength of aperture is for an antenna having zero nulls, which is unusable at most locations for gains over a value of about six. For null-filled antennas the value may be considerably below 1.22, depending upon the amount of "fill" (typical values range from 0.7 to 1.0).

Hence, it is important in considering the performance of an antenna to evaluate not only the gain but also the amount of fill and the general shape of the vertical pattern for the terrain involved.

<sup>10</sup> S. A. Schelkunoff, "Electro-magnetic Waves." (D. Van Nostrand Co., New York, 1956), Sec. 9.11, P. 348.

<sup>11</sup> This definition is not rigorous but for the common types of radiators used in television broadcast antennas is sufficiently accurate.

<sup>9</sup> H. E. Gihring, "The RCA Test Facilities for TV Antennas." *Broadcast News*, Vol. No. 102, Oct., 1958.





# new RCA magnetic disc recorder

combines advantages  
of tape and disc!

A great new tool for broadcasters... makes  
possible fast recording  
and playback of  
commercials  
and announcements

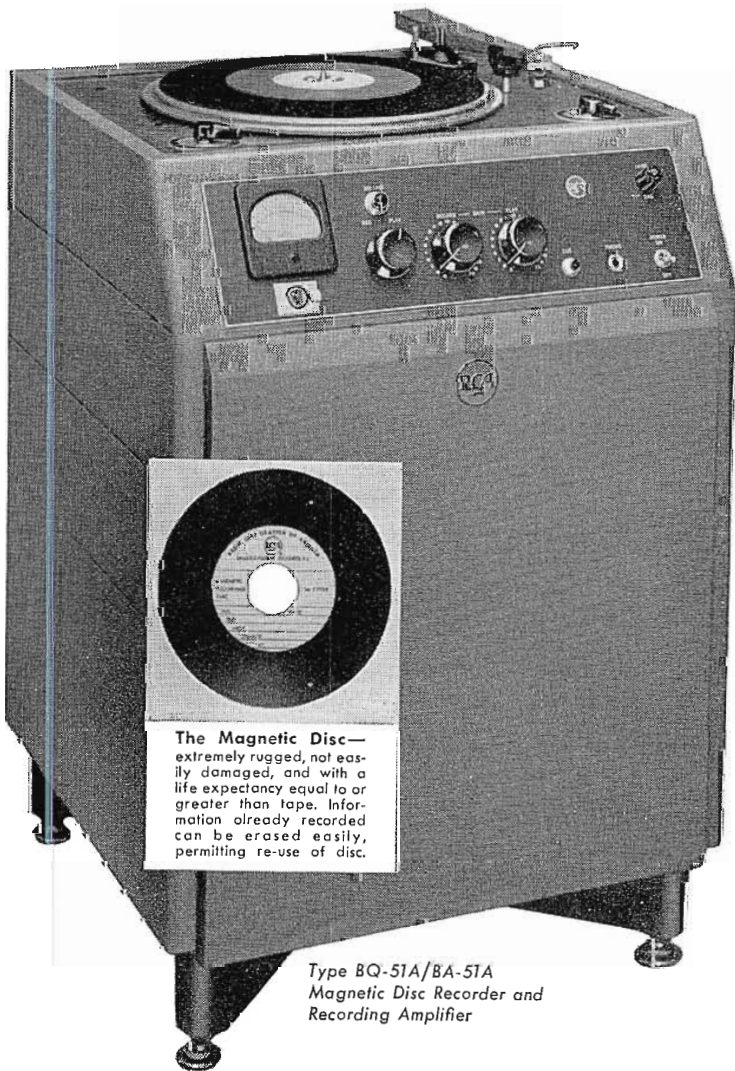

**The Magnetic Disc—**  
extremely rugged, not easily damaged, and with a life expectancy equal to or greater than tape. Information already recorded can be erased easily, permitting re-use of disc.

Type BQ-51A/BA-51A  
Magnetic Disc Recorder and  
Recording Amplifier

This new Disc Recorder, a completely self-contained unit, meets the broadcaster's requirements for fast recording and playback of commercials and announcements. Extremely simple in operation, it minimizes the skill required to produce a professional recording. Grooves for recording are molded into the blank disc. No cutting mechanisms, optical devices and heated styli are needed; the same equipment serves for recording and playback. All of the advantages of magnetic tape recording are retained in the magnetic discs, yet winding, splicing, cueing and other tape handling problems are eliminated.

A recording time of 70 seconds is obtained from each side of the magnetic disc, which includes 10 seconds for "cue-in" and "trip-out" cue tones.

The magnetic head used in the system consists of two C-shaped laminations made of a material that is extremely hard physically, but with very high permeability. A newly designed tone arm which accommodates standard MI-11874-4 (1 mil) and 11874-5 (2.5 mil) pickups also can be handled by means of a plug-in socket arrangement. It can be used for reproducing standard transcriptions and phonograph records up to 12 inches in diameter at 33 $\frac{1}{3}$  or 45 rpm.

**Magnetic Recording Head.**

The magnetic pole pieces which do the recording protrude through the narrow slot (see arrow).

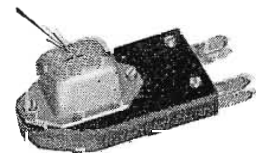

*The Magnetic Disc Recorder can be the first of the building blocks in preparing for automatic programming. For complete information on the Disc Recorder and companion units call your RCA Broadcast Representative. In Canada: RCA VICTOR Company Limited, Montreal.*



Tmk(s)®

**RADIO CORPORATION of AMERICA**

BROADCAST AND TELEVISION EQUIPMENT

CAMDEN, NEW JERSEY

# RCA 5KW FM TRANSMITTER

## TYPE BTF-5B

### DESIGNED FOR MULTIPLEXING AND REMOTE CONTROL

**THIS NEW FM TRANSMITTER** is designed for both conventional and multiplex operation. Outstanding performance features such as, a direct FM system, built-in remote control provisions, screen voltage power output control, and many others, make the BTF-5B today's best FM transmitter buy.

**ADEQUATE COVERAGE**—Its 5000-watt power output provides adequate coverage of a multiplex channel and improved coverage for conventional operation. The high power level permits the use of low-gain antennas to achieve a high ERP.

**UNIQUE EXCITER**—New FM Exciter, Type BTE-10B, uses "Direct FM" modulator circuits, thus fewer tubes are required. Automatic frequency control system with frequency detector prevents off frequency operation.

**MULTIPLEX ACCESSORIES**—Subcarrier generators for multiplex operation are available as optional equipment. There is room inside the new transmitter for mounting one of these generators. Exciter and subcarrier generators are also available as separate items for use with existing FM transmitters.

**BROADBAND ANTENNA**—New antenna designed to meet low VSWR requirements of multiplex system is available, along with a complete line of FM accessories.

★

*For all your FM needs call your nearest RCA Broadcast Representative.*

**IN CANADA:**

**RCA VICTOR Company Limited, Montreal**



#### OUTSTANDING FEATURES OF THE BTF-5B

- Designed for Remote Control
- Direct FM System
- Designed for Multiplexing
- Fewer Tubes and Tuned Circuits
- Built-in Oscilloscope for Easy Tuning
- Choice of Colors
- Matching Rack Available for Accessories and Additional Subcarrier Generator



Tmk(s) ®

**RADIO CORPORATION of AMERICA**

BROADCAST AND TELEVISION EQUIPMENT

CAMDEN, NEW JERSEY

for peak broadcasting performance . . .

# USE RCA'S QUARTER-CENTURY OF BROADCAST SERVICE EXPERIENCE

With RCA Broadcast Service you'll control your maintenance costs and be assured of . . .

## COMPLETE MAINTENANCE SERVICE

*from microphone to antenna!*

### HERE'S A PARTIAL LIST OF RCA SERVICES:

- **TRANSMITTER PERFORMANCE MEASUREMENTS**  
Test and tabulation of performance data for monochrome or color, visual and aural transmitters.
- **ANTENNA SYSTEM MEASUREMENTS**  
Impedance or VSWR and resistance measurements for evaluating performance.
- **COMPLETE ANTENNA INSPECTION**  
Mechanical inspection plus impedance, resistance and high voltage measurements.
- **MICROWAVE SERVICE**  
Signal to noise, frequency response, phase shift measurements and path alignment.
- **INSTALLATION SUPERVISION**  
Transmitters, studio equipment and antennas.
- **EQUIPMENT REPAIR SERVICE**  
TV cameras, microphones, pick-ups, consoles and related broadcast equipment.
- **TV PROJECTOR SERVICE**  
Scheduled preventive maintenance contract service.
- **GENERAL SERVICE**  
Adjustment and repair of studio and transmitting equipment.

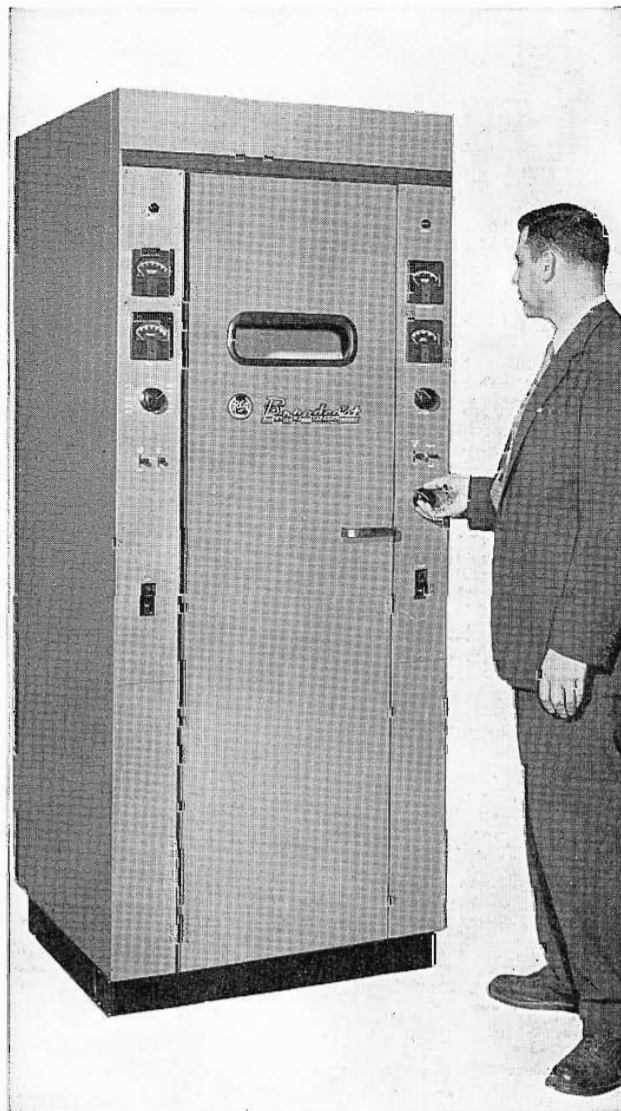

FOR THIS COMPLETE BROADCAST SERVICE, CONTACT ANY OF THE RCA SERVICE COMPANY OFFICES:

Pennsauken, New Jersey  
6710 Westfield Avenue  
Telephone: NORmandy 3-8101

Hollywood, California  
909 N. Orange Drive  
Telephone: OLDfield 4-0880

Atlanta, Georgia  
160 14th Street, N.W.  
Telephone: TRinity 4-4543

Cherry Hill, Camden 8, New Jersey  
Telephone: WOODlawn 3-8000  
Extension PY-5101

Chicago, Illinois  
1322 S. Wabash Avenue  
Telephone: WEBster 9-6117



BROADCAST SERVICE  
**RCA SERVICE COMPANY**

A Division of Radio Corporation of America  
Camden 8, New Jersey

Tmk(s) ®



Another Way  
RCA Serves  
Telecasters  
Through  
Electronics

**RCA's  
constant research  
gives TV cameras**

**better "vision"**

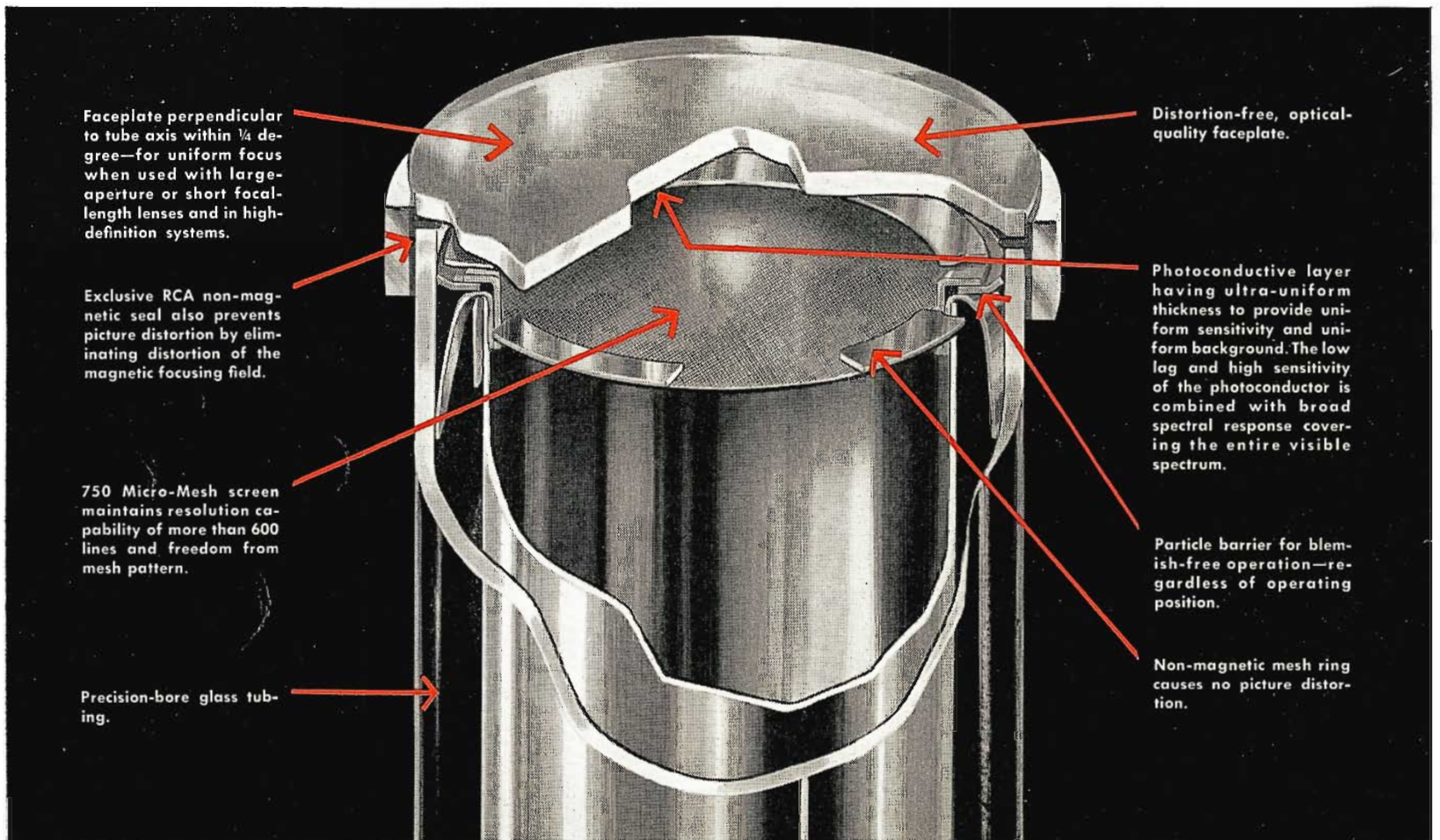

RCA tube designers originated the Image Orthicon—the tube that made modern telecasting practicable—and subsequent refinements such as Micro-Mesh and Super-Dynode. The Vidicon, too, was an RCA “first”. The same spirit of research that originated these famous camera tubes continues to improve them in performance, reliability, life.

Look at the “inside story” of the RCA-7038 Vidicon, for instance. Here you see the latest improvements in Vidicon

design and manufacture—backed by 25 years of camera tube experience. High sensitivity and uniformity over the entire scanned area open new possibilities in live-and film-pick-up camera techniques.

For the best in TV camera tubes, see your nearest RCA Tube Distributor. He’s set up to serve all your camera tube needs. He’s also ready and able to handle your audio needs including high quality RCA Sound Tape. Call him for prompt delivery.



**RADIO CORPORATION OF AMERICA**

*Electron Tube Division*

*Harrison, N. J.*